

**NATIONAL INSTITUTES OF HEALTH  
LABORATORY SAFETY MONOGRAPH**

*A SUPPLEMENT  
TO THE  
NIH GUIDELINES FOR RECOMBINANT DNA RESEARCH*

---

**July 1978**

# **LABORATORY SAFETY MONOGRAPH**

## **A SUPPLEMENT TO THE NIH GUIDELINES FOR RECOMBINANT DNA RESEARCH**

Prepared by the  
Office of Research Safety  
National Cancer Institute  
and the  
Special Committee of Safety and Health Experts

National Institutes of Health  
Bethesda, Maryland

July 1978

U.S. Department of Health, Education, and Welfare  
Public Health Service  
National Institutes of Health

SPECIAL COMMITTEE OF SAFETY AND HEALTH EXPERTS

W. Emmett Barkley, PhD	Director, Office of Research Safety National Cancer Institute, NIH (Chairman)
Manuel S. Barbeito, BS	Assistant Safety Manager Office of Research Safety National Cancer Institute, NIH
Robert J. Brandt, MD	Medical Director Occupational Medical Service, NIH
Everett Hanel, Jr., BA	Head, Environmental Control Section Frederick Cancer Research Center
Leon S. Idoine, MPH	Head, Safety Information Program Frederick Cancer Research Center
G. S. Michaelsen, MSChE	Assistant Safety Manager Office of Research Safety National Cancer Institute, NIH
Vinson R. Oviatt, MPH	Chief, Environmental Safety Branch Division of Research Services, NIH
Warren V. Powell, MPH	Chief, Biological Control Section Environmental Safety Branch Division of Research Services, NIH
John H. Richardson, DVM	Director, Office of Biosafety Center for Disease Control
James F. Sullivan, DVM	Veterinary Medical Officer National Animal Disease Center

## Preface

The "Laboratory Safety Monograph—A Supplement to the NIH Guidelines for Recombinant DNA Research" is a revised and expanded edition of "Appendix D, Supplementary Information on Physical Containment," which was published June 23, 1976, as a part of the "NIH Guidelines for Recombinant DNA Research." This monograph was prepared in response to numerous requests for greater specificity in describing practices, equipment, and facilities appropriate for the safe conduct of recombinant DNA research.

The principal purpose of the "Laboratory Safety Monograph" is to assist scientific institutions, principal investigators, and health and safety professionals in the selection and use of physical containment measures described in the revised "NIH Guidelines for Recombinant DNA Research." The information provided in this monograph is based on established principles of laboratory safety, expert opinion, and experience in dealing safely with infectious disease organisms in diagnostic and research laboratories. The monograph will be useful, therefore, not only to those associated with recombinant DNA research, but to all who are associated with research programs involving potentially hazardous organisms.



Donald S. Fredrickson  
Director, NIH

LABORATORY SAFETY MONOGRAPH  
 A SUPPLEMENT TO THE NIH GUIDELINES FOR RECOMBINANT DNA RESEARCH

I. Introduction. . . . .	1
II. Laboratory Practices. . . . .	3
A. Laboratory Techniques for Biohazard Control . . . . .	3
1. Pipetting . . . . .	5
2. Syringes and Needles. . . . .	13
3. Freeze-Drying Specimens . . . . .	15
4. Opening Culture Plates, Tubes, Bottles, and Ampoules, Inoculating and Harvesting Cultures . . . . .	17
5. Centrifuging. . . . .	20
6. Blenders, Mixers, Sonicators and Cell Disruption Equipment . . . . .	32
7. Miscellaneous Precautions and Recommendations . . . . .	37
References. . . . .	39
B. Personal Hygiene Habits and Practices . . . . .	43
References. . . . .	45
C. Protective Clothing and Equipment . . . . .	46
1. Laboratory Clothing . . . . .	49
2. Gloves, Shoes and Aprons. . . . .	54
3. Face and Eye Protection . . . . .	61
4. Respiratory Protective Equipment. . . . .	65
5. Positive Pressure Suits . . . . .	71
D. Housekeeping. . . . .	73
1. Floor Care. . . . .	76
2. Dry Sweeping. . . . .	77
3. Vacuum Cleaning . . . . .	78
4. Selection of a Cleaning Solution. . . . .	80
5. Wet Mopping--Two-Bucket Method. . . . .	81
6. Alternative Floor Cleaning Method for Animal Care Areas and Areas with Monolithic Floors. . . . .	82
E. Decontamination and Disposal. . . . .	83
1. Disinfectant Methods. . . . .	84
2. Characteristics of Chemical Disinfectants in Common Use in Laboratory Operations. . . . .	87
3. Properties of Some Common Disinfectants . . . . .	89
4. Vapors and Gases for Space Decontamination. . . . .	92

5.	Residual Action of Disinfectants. . . . .	95
6.	Laboratory Spills . . . . .	96
7.	Disposal. . . . .	100
8.	Selecting Chemical Disinfectants in Recombinant DNA Research . . . . .	102
9.	Caution Required When Applying Disinfectant Methods. . . . .	106
F.	Care and Use of Laboratory Animals. . . . .	108
1.	Care and Handling of Infected Animals . . . . .	109
2.	General Guidelines that Apply to Animal Room Maintenance . . . . .	111
3.	Necropsy Rules for Infected Animals . . . . .	112
G.	Biohazard Symbol and Its Use. . . . .	113
H.	Protection of Vacuum Systems When Filtering Biohazardous Materials . . . . .	117
III.	Containment Equipment . . . . .	121
A.	The Biological Safety Cabinet . . . . .	121
1.	Class I Biological Safety Cabinet . . . . .	123
2.	Class II Biological Safety Cabinet. . . . .	125
3.	Class III Biological Safety Cabinet . . . . .	128
B.	Certification Procedures. . . . .	130
1.	Certification of the Face Velocity of the Class I Cabinet. . . . .	132
2.	Certification of the Face Velocity of the Class II, Type A Cabinet . . . . .	133
3.	Certification of the Face Velocity of the Class II, Type B Cabinet . . . . .	134
4.	Certification of the Velocity Profile of the Class II Cabinet . . . . .	135
5.	Certification of the Leak Tightness of the Class II, Type A Cabinet . . . . .	136
6.	Certification of Leak Tightness of the Class III Cabinet Systems. . . . .	138
7.	Leak Testing of High-Efficiency Particulate Air Filters (HEPA) . . . . .	142
8.	Certification of the Operational Negative Air Pressure in the Class III Biological Safety Cabinet System. . . . .	145
IV.	Special Laboratory Design . . . . .	147
A.	The P3 Facility . . . . .	148
B.	The P4 Facility . . . . .	151
C.	Certification Procedures. . . . .	156

1.	Certification of Leak Tightness of Penetration Seals for P4 Suit Rooms Without Primary Barriers . . . . .	158
2.	Certification of Directional Airflow. . . . .	160
3.	Certification of Negative Pressure Within P4 Suit Areas . . . . .	161
4.	Certification of the Leak Tightness of Exhaust Air Ducts from the P4 Suit Area. . . . .	162
5.	Certification of Leak Tightness of General Exhaust Air Ducts (New Construction) . . . . .	164
6.	Certification of Steam and Ethylene Oxide Sterilizers. . . . .	167
7.	Leak Testing of High-Efficiency Particulate Air (HEPA) Filters . . . . .	170
8.	Certification of the P4 Facility Liquid Biowaste Treatment System. . . . .	171
V.	Packaging and Shipping of Recombinant DNA Materials . . . . .	173
VI.	Roles and Responsibilities. . . . .	181
	A. The Institutional Biosafety Committee . . . . .	181
	B. The Biological Safety Officer . . . . .	191
	C. Emergency Procedures. . . . .	194
	D. Medical Surveillance. . . . .	196
	E. Training Aids, Materials and Courses. . . . .	206
	F. Reference Bibliography on Biological Safety . . . . .	210
VII.	NCI Guidelines for Control of Moderate Risk Oncogenic Viruses. . . . .	222

## I. Introduction

The scientific community has long recognized the need to employ physical containment measures when conducting research with biological materials. Historically, the development and use of containment techniques began as an effort to secure and maintain pure cultures of bacteria; it was not until human laboratory-acquired infections began to appear that attention was given to the protection of personnel. For example, the frequency of typhoid among laboratory workers at the turn of the century caused by pipetting accidents, stimulated the development of mechanical pipetting aids. Since these early beginnings, a significant body of information has been developed by scientists and safety professionals, alike, which can be used today to guide laboratory workers in the safe conduct of research with potentially hazardous organisms. It is this body of information on which the "Laboratory Safety Monograph, a Supplement to the NIH Guidelines for Recombinant DNA Research" is based.

The "Laboratory Safety Monograph" provides information on physical containment measures that are applicable to recombinant DNA research. The monograph has been organized to complement the "NIH Guidelines for Recombinant DNA Research." Major sections of the monograph deal with laboratory practices, containment equipment, special laboratory design, and roles and responsibilities. The section on laboratory practices has information on specific techniques used by the laboratory worker in the control of biohazards. The section on containment equipment reviews Biological Safety Cabinets and describes their capabilities and limitations. This section also provides definitive procedures for certifying the containment capability of Biological Safety Cabinets. The special laboratory design section amplifies design considerations for P3 and P4 facilities; certification procedures for important facility safeguards are presented in this section. The section on roles and responsibilities emphasizes the activities of the Institutional Biosafety Committee and the biological safety officer. Guidance concerning emergency procedures and medical surveillance is provided. This section also



identifies specific training resources and provides a reference bibliography on biological safety. The monograph also includes guidelines for the control of moderate risk oncogenic viruses and information on packaging and shipping of recombinant DNA materials.

Experience has demonstrated that the safe conduct of research involving potentially hazardous organisms is dependent on good laboratory practice, the availability and use of containment equipment, the design and operation of the research facility, and effective management. These are the subject areas to which this monograph has been addressed. It is hoped that this information will be of value to all concerned with the safe conduct of recombinant DNA research.

Finally, the suggestions and recommendations presented in the monograph are advisory in nature; they do not constitute mandatory requirements. An important intent of the monograph is to encourage investigators, safety professionals and institutional officials to seek new and better methods of biohazard control and to apply professional judgement in the interpretation of the physical containment requirements of the "NIH Guidelines for Recombinant DNA Research."

Note: This monograph names and illustrates representative materials, processes, and equipment only, and should not be considered as an all-inclusive listing. Names of commercial manufacturers and trade names are provided as examples only, and their inclusion does not constitute or imply approval or endorsement; nor does the exclusion of commercial manufacturers' names and trade names constitute or imply nonapproval or nonendorsement by the National Institutes of Health, Public Health Service, U.S. Department of Health, Education, and Welfare.

## II. Laboratory Practices

### A. Laboratory Techniques for Biohazard Control

Analysis of comprehensive surveys of laboratory-acquired infections (1)\* indicates that fewer than 20 percent of known infections can be attributed to a documented accidental exposure. Risk assessment studies, however, have demonstrated that aerosols are created by most laboratory manipulations that involve microorganisms (2-5). These results suggest that inhalation of undetected aerosols may have contributed to occupational illness among laboratory workers who have handled biohazardous materials (6,7).

Laboratory techniques for operations that have a high potential for creating aerosols are reviewed in this section. Four measures are recommended to decrease the hazard of exposure to aerosols.

#### MEASURES TO DECREASE HAZARDS OF AEROSOLS FROM LABORATORY OPERATIONS

Operations that have the potential to create hazardous aerosols	Measures to decrease hazards from aerosols:			
	Avoid creating aerosol	Reduce extent of aerosol	Contain aerosol	Use personal respiratory protection
blowing the last drop of a liquid culture or chemical from a pipette	●			
removing the cover from a Waring blender or dry chemical grinder shortly after completion of the blending or grinding operation		●	●	
removing the cap from a bottle of a liquid culture or suspension immediately after vigorous shaking; improper stoppering of volatile toxic substances		●	●	
grinding tissue with mortar and pestle or glass tissue grinder		●	●	
decanting the supernatant fluid after centrifugation	●	●		
resuspending packed cells by shaking or mixing		●	●	
inserting a hot wire loop in a culture	●	●		
withdrawing a culture sample from a vaccine bottle	●	●		
opening a freeze-dried preparation		●	●	
shaking and blending cultures and infected tissues in high-speed mixers		●	●	
disrupting tissue cultures to release virus by shaking with glass beads		●	●	
streaking an inoculum on a rough agar surface	●			
sonic disruption of cells		●	●	
inoculating mice via the intranasal or other routes		●	●	
harvesting cultures from embryonated eggs	●	●	●	
evacuating the atmosphere from a high-vacuum steam sterilizer prior to sterilization of contaminated material	●	●		
removing cotton plugs from flasks and centrifuge tubes		●		
handling cages that held infected animals		●	●	●
handling large animals in open areas or in unventilated cages		●		●

\*The references for this section appear on page 39.

Measures that avoid the creation of an aerosol or reduce the extent of aerosol formation should be employed routinely. Measures that contain the aerosol are to be used when the research activity requires physical containment at levels of P2 and above.

## 1. Pipetting

Pipettes are basic scientific pieces of equipment used throughout the world. They are used for volumetric measurement of fluids and for the transfer of these fluids from one container to another. The fluids that are handled are frequently hazardous in nature, containing infectious, toxic, corrosive or radioactive agents. A pipette can become a hazardous piece of equipment if improperly used. Safety pipetting techniques are required to reduce the potential for exposure to hazardous materials. The most common hazards associated with pipetting procedures involve the application of mouth suction. The causative event in more than 13 percent of all known laboratory accidents that resulted in infection was oral aspiration through a pipette. Contaminants can be transferred to the mouth if a contaminated finger is placed on the suction end of the pipette. There is also the danger of inhaling aerosols created in the handling of liquid suspensions when using unplugged pipettes, even if no liquid is drawn into the mouth. Additional hazards of exposure to aerosols are created by liquid dropping from a pipette to a work surface, by mixing cultures by alternate suction and blowing, by forceful ejection of an inoculum onto a culture dish, or by blowing out the last drop. It has been demonstrated by high-speed photography that an aerosol of approximately 15,000 droplets, most under ten micrometers, is produced when the last drop of fluid in the tip of the pipette is blown out with moderate force. While the aerosol hazard associated with pipetting procedures can only be reduced by use of safe techniques and of Biological Safety Cabinets, the potential hazards associated with oral ingestion can be eliminated by use of mechanical pipetting aids.

### a. Safety Pipetting Aids

There are many commercially available safety pipetting aids that can be used. A particular type of pipetting aid that may be satisfactory to one individual or kind of operation may not meet the requirements of others; therefore, different types should be tried in each

situation. Ease of manipulation and accuracy of delivery by the aids are important factors in their selection. Care should be taken in selecting a device that its design or use does not contribute to exposure to hazardous contaminants, that exposed parts (other than delivery tips) are kept free of hazardous substances, and that the unit can be easily sterilized and cleaned after use. Any device requiring mouth suction should be considered unsafe.

For research activities, there is no standard safety pipetting aid; instead, there is a wide choice of hand-held, nonautomatic devices to meet different needs. Nonautomatic pipetting aids are available in a variety of bulb-actuated suction devices and piston or syringe types. Some may be designed to provide easy repetitive withdrawal of aliquots of a fluid. Many of those that are in use are illustrated below. Others are available and new ones are developed and put on the market each year. Detailed information on these products can be obtained by writing to the manufacturer.

The pipetting aids used in biomedical and chemical laboratories can be classified into three categories: ultramicro (<0.1 ml); micro (0.1 ml to 1 ml), and macro (>1 ml). Some systems use disposable tips and some a small vacuum pump. The latter incorporates a separate high-efficiency particulate air (HEPA) filter system intended to prevent the escape of any potential hazardous aerosol; the nosepiece contains a "fail safe" check valve for preventing the sample from being accidentally drawn into the handle or pump. In selecting a pipetting aid, consideration should be given to whether the unit can be sterilized with steam and to the ease of reading the meniscus, controlling the flow of fluid, filling, discharging, and changing pipettes. Other desirable features of design are that it not contribute to fatigue of the finger and wrist, that it leaves the third and fourth fingers free to manipulate plugs and bottle caps, and that it not contribute to lack of control and cause leaking.

Sources and prices (1977) are given in the table following the illustrations.

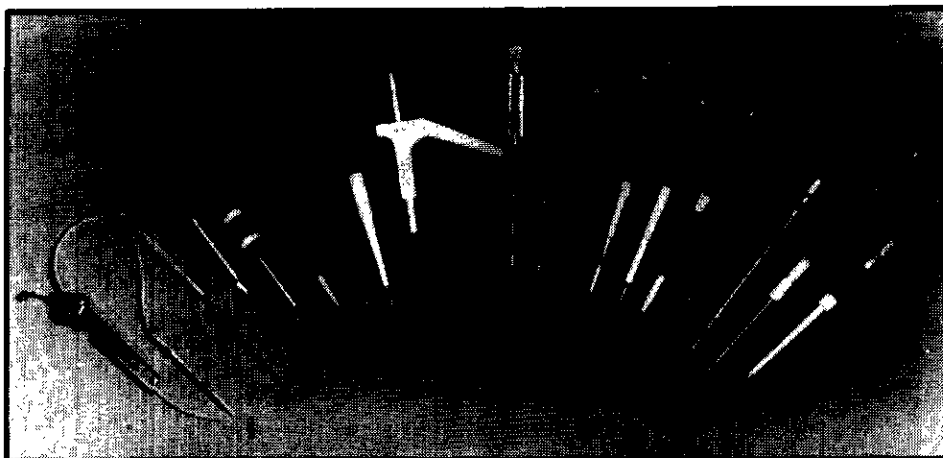

- |                                       |  |   |
|---------------------------------------|--|---|
| 1 Clinac Safety Pipettor              | 8 Clay Adams-Micro Selectapette                          | 14 Oxford Sampler Ultramicropipette   |
| 2 Sargent-Weich Pipette Syringe       | 9 Lancer Precision Pipettor                              | 15 Elkay "Socorex" Micro Pipette (Swiss manufactured)                       |
| 3 Drummond Dialomatic Micro Dispenser | 10 MLA Pipettor  | 16 Centaur Pipet  |
| 4 Hamilton Ultra Micro Syringe Pipet  | 11 Eppendorf Microliter Pipet (West German manufactured) | 17 Oxford Sampler Pipette, Model Q  |
| 5 Unimetrics Micropipettor            | 12 Pipetman Ultra Micro Pipette (French manufactured)    | 18 Gilson/Rainin Pipetman, Digital Dispensing Pipette (French manufactured) |
| 6 Finnpiquette (Finnish manufactured) | 13 Oxford Sampler Pipette (8000 Series)                  |   |
| 7 Helena Quickpette                   |  |   |

#### ULTRAMICRO PIPETTING AIDS

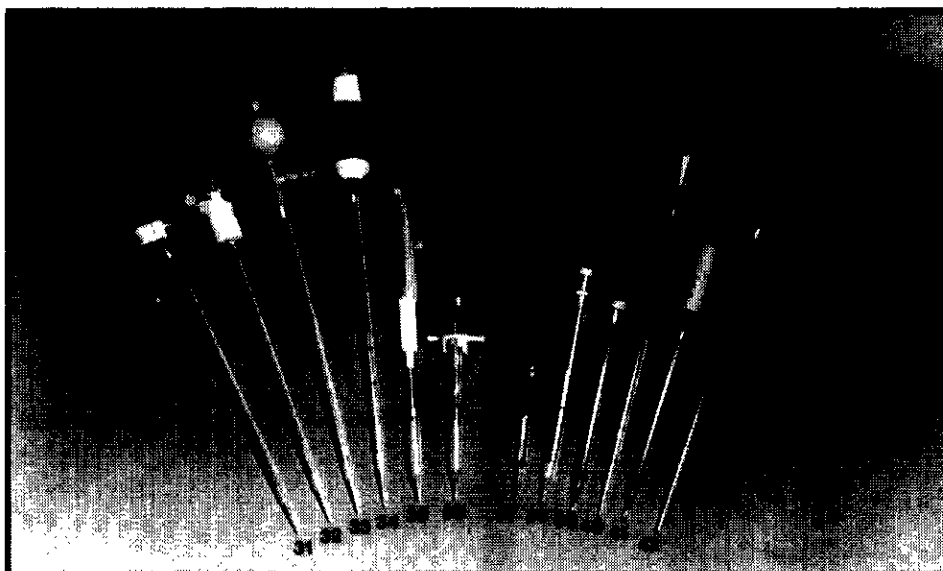

- |  |  |
|--|--|
| 31 National Instrument Micropipet Pipettor (French manufactured) | 37 Labindustries Micro/Mac Pipet                             |
| 32 Pumpett 25, Original (Swedish manufactured)                   | 38 Centaur   |
| 33 Spectroline Pipette Filler                                    | 39 Interex Rubber Transfer Bulb                              |
| 34 Manostat Accropet Filler (Macro)                              | 40 Volac Universal Pipette Controller (British manufactured) |
| 35 Oxford Macro Set Transfer Pipetting System                    | 41 Nalgene Pipetting Aid                                     |
| 36 Lab Industries Repipet Jr Sampler                             | 42 Pi Pump (West German manufactured)                        |

#### MICRO PIPETTING AIDS

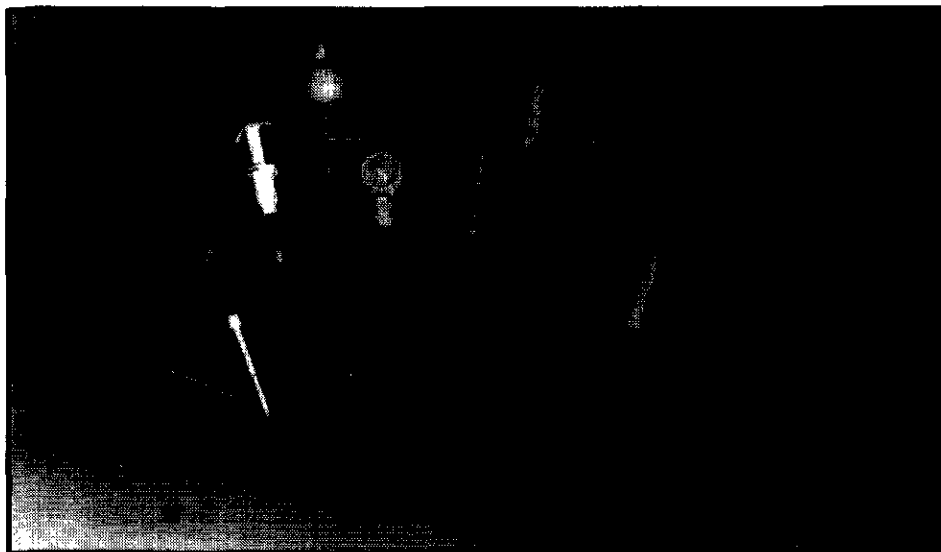

- |   |   |  |
|---|---|--|
| 19 Biopipette Automatic Pipette   | 23 Pumpett 18<br>(Swedish manufactured) | 27 Analytic Products Safety Bulb           |
| 20 Gilson/Rainin Pipetman, Digital<br>Dispensing Pipette<br>(French manufactured) | 24 Curtin Matheson Rubber Pipet Bulb    | 28 Clay Adams Pipet Suction<br>Apparatus   |
| 21 Manostat Vari-Pet  | 25 Demuth Safety Pipet                  | 29 Manostat Accropet Filler                |
| 22 Spectroline Pipette Filler   | 26 Nalgene Pipetting Aid                | 30 Cornwall Continuous Pipetting<br>Outfit |

### MACRO PIPETTING AIDS

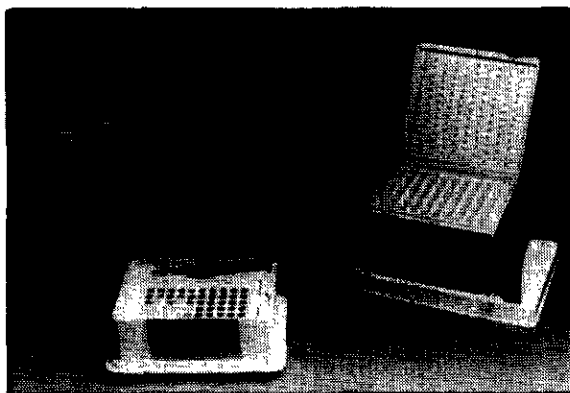

- 43 MLA Inc. Pipetting System
- 44 Clay Adams Selectapette Pipet System
- 45 Centaur Pipet System

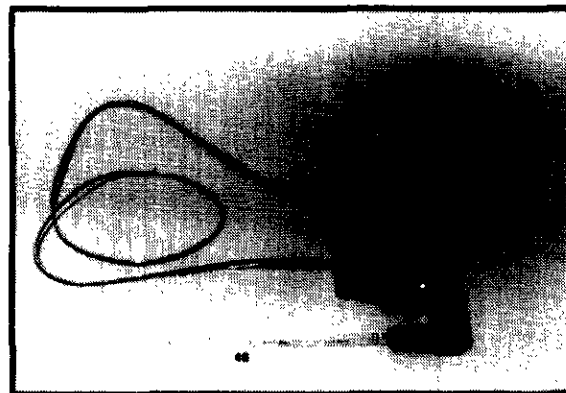

- 46 Drummond Pipet-Aid

### PIPETTING AID SYSTEMS

### SOURCES OF PIPETTING AIDS

Item / Source	Figure Legend Numbers	Price Range*	Item / Source	Figure Legend Numbers	Price Range*
Analytic Products Safety Bulb Analytical Products, Inc. P.O. Box 845 Belmont, CA 94002	27	C	Drummond Pipet-Aid	46	J
Biopipette Automatic Pipette Schwartz/Mann Division of Becton, Dickinson & Co. Orangeburg, NY 10962	19	I	Elkay "Socorex" Micro Pipette (Swiss manufactured) Elkay Products, Inc. 95 Grand Street Worcester, MA 01610	15	H
Centaur Pipet Centaur Chemical Company 180 Harvard Avenue Stanford, CT 06902	16, 38	G, H	Eppendorf Microliter Pipet (West German manufactured) Brinkman Instruments, Inc. Cautrague Road Westbury, NY 11590	11	H
Centaur Pipet System	45	H	Finnpipette (Finnish manufactured) Variable Volumetrics, Inc. 17 Cummings Park Woburn, MA 01801	6	I
Clay Adams-Micro Selectapette Clay Adams Division of Becton, Dickinson & Co. Parsippany, NJ 07054	8	I	Gifson/Rainin Pipetman, Digital Dispensing Pipette (French manufactured) Rainin Instrument Company, Inc. 94 Lincoln Street Brighton, MA 02135	18, 20	I
Clay Adams Pipet Suction Apparatus	28	C	Hamilton Ultra Micro Syringe Pipet Hamilton Company P.O. Box 7500 Reno, NV 89502	4	H
Clay Adams Selectapette Pipet System	44	I	Helena Quickpette Helena Laboratories P.O. Box 752 Beaumont, TX 77704	7	H
Clinac Safety Pipettor LaPine Scientific Company 6001 South Knox Avenue Chicago, IL 60629	1	E	Interex Rubber Transfer Bulb Interex Corporation 3 Strathmore Road Natick, MA 01760	39	A
Cornwall Continuous Pipetting Outfit Curtin Matheson Scientific Co. P.O. Box 1546 Houston, Texas 77001	30	E	Labindustries Micro/Mac Pipet Labindustries 1802 Second Street Berkeley, CA 94710	37	B (glass) A (rubber)
Curtin Matheson Rubber Pipet Bulb Curtin Matheson Scientific Co. P.O. Box 1546 Houston, Texas 77001	24	A	Labindustries Repipet Sampler	36	E
Demuth Safety Pipet Demuth Glass Division Brockway Glass Company, Inc. Route 1, Box 13 Parkersburg, WV 26101	25	A	Lancer Precision Pipettor Sherwood Medical Industries 1831 Olive Street St. Louis, MO 63103	9	H
Drummond Dialomatic Micro Dispenser Drummond Scientific Company 500 Parkway Broomall, PA 19008	3	H			



**SOURCES OF PIPETTING AIDS (Continued)**

Item / Source	Figure Legend Numbers	Price Range*	Item / Source	Figure Legend Numbers	Price Range*
Manostat Accropet Filler Manostat Corporation 519 Eighth Avenue New York, NY 10018	29, 34	C	Pi Pump (West German manufactured) Bel Art Products Pequannock, NJ 07440	42	D
Manostat Vari-Pet	21	G	Pipetman Ultra Micro Pipette (French manufactured) Analtech, Inc. 75 Blue Hen Drive Newark, DE 19711	12	I
MLA Pipettor & Pipettor System Medical Laboratory Automation, Inc. 520 Nuber Avenue Mount Vernon, NY 10550	10, 43	H, I	Pumpett 18 (Swedish manufactured) LaPine Scientific Company 6001 South Knox Avenue Chicago, IL 60629	23	C
Nalgene Pipetting Aid (West German manufactured) Nalgene Labware Division Nalge Sybron Corporation P.O. Box 365 Rochester, NY 14602	26, 41	D	Pumpett 25, Original (Swedish manufactured)	32	C
National Instrument Micropipet Pipettor (French manufactured) National Instrument Co., Inc. 4119 Fordleigh Road Baltimore, MD 21215	31	D	Sargent-Welch Pipette Syringe Sargent-Welch Scientific Co. 7300 North Linder Avenue Skokie, IL 60076	2	D
Oxford Macro Set Transfer Pipetting System Oxford Laboratories 1149 Chess Drive Foster City, CA 94404	35	I	Spectroline Pipette Filler Arthur H. Thomas Company Vine Street at 3rd P.O. Box 779 Philadelphia, PA 19105	33, 22	D
Oxford Sampler Pipette (8000 Series)	13	H	Unimetrics Micro-pipettor Unimetrics Corporation 1853 Raymond Avenue Anaheim, CA 92801	5	I
Oxford Sampler Pipette, Model Q	17	H	Volac Universal Pipette Controller (British manufactured) Cole-Parmer Instrument Company 7425 North Oak Park Avenue Chicago, IL 60648	40	D
Oxford Sampler Ultramicropipette	14	H			

**\*PRICE RANGES**

A \$ 5.00 or less	E \$10.01 - \$25.00	H \$ 30.01 - \$ 50.00
B \$ 1.00 - \$10.00	F \$20.01 - \$30.00	I \$ 50.01 - \$100.00
C \$ 5.01 - \$10.00	G \$25.01 - \$50.00	J \$100.00 or more
D \$10.01 - \$20.00		

The older conventional transfer and serological pipettes are difficult to use in safety cabinets because of their length. In these instances, select an appropriate short pipette from those now commercially available.

When it is necessary to insert the suction end of the pipette into the pipetting aid, this can be done more easily if the suction end is first wetted by a small sponge soaked in a disinfectant. This will also assist in achieving an airtight closure.

Prospective users of pipetting aids must be cautioned that no independent studies have been reported on the quantitative assessment of the safety performance of the aids. It is desirable that such studies be undertaken within each laboratory group for its particular operation. The parameters that deserve attention in a safety evaluation involve the ability of the pipetting aid:

- To perform without uncontrollable discharge (i.e., leakage) from the pipette or disposable tip.
- To function without contamination of the suction end of the pipette and, in turn, the pipetting aid, operator and vacuum lines.
- To transfer fluids without creating aerosols that spread surface contamination and result in inhalation and ingestion of hazardous substances.
- To be cleaned and sterilized in routine maintenance and preventive operations or following overt accidental contamination.

b. Safe practices governing the use of pipettes and pipetting aids.

(1) Never use mouth pipetting. Always use some type of pipetting aid.

(2) If working with biohazardous or toxic fluids, pipetting operations should be confined to a safety cabinet or hood.

(3) Pipettes used for the pipetting of biohazardous or toxic materials always should be plugged with cotton (even when safety pipetting aids are used).

(4) No biohazardous material should be prepared by bubbling expiratory air through a liquid with a pipette.

(5) Biohazardous material should not be mixed by suction and expulsion through a pipette.

(6) No biohazardous material should be forcibly expelled out of a pipette.

(7) When pipettes are used, avoid accidentally dropping infectious cultures from the pipette. Place a disinfectant-soaked towel on the working surface and autoclave the towel after use.

(8) Mark-to-mark pipettes are preferable to other types, since they do not require expulsion of the last drop.

(9) Discharge from pipettes should be as close as possible to the fluid or agar level, or the contents should be allowed to run down the wall of the tube or bottle whenever possible, not dropped from a height.

(10) Contaminated pipettes should be placed horizontally in a pan containing enough suitable disinfectant to allow complete immersion. They should not be placed vertically in a cylinder.

(11) Discard pans for used pipettes are to be housed within the Biological Safety Cabinet.

(12) The pan and pipettes should be autoclaved as a unit. The replacement unit should be a clean pan with fresh disinfectant.

## 2. Syringes and Needles (8)

The hypodermic needle is a dangerous instrument. To lessen the chance of accidental injection, aerosol production or spills, its use should be avoided when alternate methods are available. For example, use a blunt needle or a cannula on the syringe for oral or intranasal inoculations and never use a syringe and needle as a substitute for a pipette in making dilutions of dangerous fluids.

The following practices are recommended for use of the hypodermic needle and syringe when used for parenteral injections:

- Use the syringe and needle in a Biological Safety Cabinet only and avoid quick and unnecessary movements of the hand holding the syringe.
- Examine glass syringes for chips and cracks, and needles for barbs and plugs. This should be done prior to sterilization before use.
- Use needle-locking (Luer-Lok<sup>R</sup> type) syringes only, and be sure that the needle is locked securely into the barrel. A disposable syringe-needle unit (where the needle is an integral part of the unit) is preferred.
- Wear surgical or other type rubber gloves for all manipulations with needles and syringes.
- Fill the syringe carefully to minimize air bubbles and frothing of the inoculum.
- Expel excess air, liquid and bubbles from a syringe vertically into a cotton pledget moistened with the proper disinfectant, or into a small bottle of sterile cotton.
- Do not use the syringe to expel forcefully a stream of infectious fluid into an open vial or tube for the purpose of mixing. Mixing with a syringe is condoned only if the tip of the needle is held below the surface of the fluid in the tube.
- If syringes are filled from test tubes, take care not to contaminate the hub of the needle, as this may result in transfer of infectious material to the fingers.
- When removing a syringe and needle from a rubber-stoppered bottle, wrap the needle and stopper in a cotton pledget moistened with the proper disinfectant. If there is danger of the disinfectant contaminating sensitive experimental materials, a sterile dry pledget may be used and discarded immediately into disinfectant solution.

- Inoculate animals with the hand "behind" the needle to avoid punctures.
- Be sure the animal is properly restrained prior to the inoculation, and be on the alert for any unexpected movements of the animal.
- Before and after injection of an animal, swab the site of injection with a disinfectant.
- Discard syringes into a pan of disinfectant without removing the needle or manually replacing the protective needle sheath that is furnished with disposable hypodermic needles or syringe-needle units. The syringe may be filled with disinfectant by immersing the needle and slowly withdrawing the plunger, and finally removing the plunger and placing it separately into the disinfectant. The filling action clears the needle and dilutes the contents of the syringe. Autoclave syringes and needles in the pan of disinfectant.
- In instances where the protective needle sheath must be replaced following use of a syringe (e.g., blood samples drawn for diagnostic purposes), forceps should always be used to minimize the possibility of exposure via accidental autoinoculation.
- Use separate pans of disinfectant for disposable and nondisposable syringes and needles to eliminate a sorting problem in the service area.
- Do not discard syringes and needles into pans containing pipettes or other glassware that must be sorted out from the syringes and needles.

### 3. Freeze-Drying Specimens

Specimens shell-frozen in ampoules, are dried on a vacuum manifold or in a chamber-type drier at low negative pressure. If the glass neck of the ampoule is sealed off while it is still under vacuum, it may cause implosion either during sealing or later when the evacuated ampoule is being opened. To avoid this, after drying is completed and before sealing is done bring the pressure within the ampoule back to normal by gradually introducing dry nitrogen, avoiding turbulent disturbance of the dry product.

The narrow or constricted neck of ampoules is contaminated if the specimen is allowed to run down the wall of the neck during filling. Subsequently, when the ampoule is sealed with a torch, the dried material on the wall becomes charred or partially decomposed; residues of this material may adversely affect the dried material when it is reconstituted. To avoid this, a syringe with a long cannula or a Pasteur-type pipette should be used to fill the vial. Do not allow the delivery end of the cannula or pipette to touch the neck of the vial.

All ampoules used for freeze-drying of cultures, toxins or other hazardous materials should be fabricated in Pyrex-type glass. This glass requires a high-temperature torch using an air-gas or oxygen-gas mixture for sealing. These hard glass ampoules are much less apt to form glass bubbles that burst inwardly during sealing under vacuum than the soft glass ampoules and, of course, are more resistant to breakage from heat-shock, handling and storage.

The freeze-drier tubes, manifold, condenser pump and other internal parts will be contaminated after use (9). When dry infectious organisms are being prepared, a significant biohazard exists. Whether infectious or noninfectious living organisms, or toxic or nontoxic nonliving agents are being treated, if purity of product is a major concern, decontamination should be carefully considered. Protection by use of air filters should be given to vacuum lines and oil pumps. Freon-ethylene oxide gas, steam sterilizing, and liquid decontaminants should be employed as

appropriate, depending on the biological or chemical agent in use and the composition of mechanical parts of the drier.

The changer-type freeze-driers allow the use of automatic plugging and screw-capping of vials and also the use of tray-drying in place of drying in ampoules or vials. The biohazards and chances of product contamination still exist and must be considered as with manifold-drying systems.

Protection against contamination of vacuum lines and pumps should be provided by appropriate filter systems.

The filling of ampoules and vials with infectious specimens and subsequent freeze-drying and sealing or closing of glass ampoules and vials in the preparation of dry infectious specimens should be done in a Biological Safety Cabinet. The same is true for preparation of ampoules and vials of liquid specimens not subjected to freeze-drying.

#### 4. Opening Culture Plates, Tubes, Bottles, and Ampoules; Inoculating and Harvesting Cultures.

In the absence of definite accidents or obvious spillage, it is not certain that opening of plates, tubes and bottles of other microorganisms has caused laboratory infection. However, it is probable that among the highly infective agents some infections have occurred by this means (9). Particular care is required when opening plates, tubes, or bottles containing fungi, for this operation may release a large number of spores. Such cultures should be manipulated in a Biological Safety Cabinet (10,11).

To assure a homogenous suspension that will provide a representative sample, liquid cultures are agitated before a sample is taken. Vigorous shaking will create a heavy aerosol. A swirling action will generally create a homogenous suspension with a minimum of aerosol. When a liquid culture is resuspended, a few minutes should elapse prior to opening the container to reduce the aerosol.

The insertion of a sterile, hot wire loop or needle into a liquid or slant culture can cause spattering and release of an aerosol. To minimize the aerosol production, the loop should be allowed to cool in the air or be cooled by touching it to the inside of the container or to the agar surface where no growth is evident prior to contact with the culture or colony. Following use of the inoculating loop or needle, it is preferable to sterilize the instrument in an electric or gas incinerator specifically designed for this purpose rather than heating in an open flame. These small incinerators have a shield to contain any material that may spatter from the loop. Disposable inoculating loops are available commercially. Rather than decontaminating them immediately after use with heat, they are discarded first into a disinfectant solution.

The practice of streaking an inoculum on rough agar results in aerosol production, created by the vibrating loop or needle. This generally does not occur if the operation is performed on smooth agar. It is good safety practice to discard all rough agar poured plates that are intended for streaking purposes with a wire loop.



Water of syneresis in petri dish cultures usually contains viable microorganisms and forms a film between the rim and lid of the inverted plate. Aerosols are dispersed when this film is broken by opening the plate. Vented plastic petri dishes where the lid touches the rim at only three points are less likely to offer this hazard (12). The risk may also be minimized by using properly dried plates, but even these (when incubated anaerobically) are likely to be wet after removal from an anaerobic jar. Filter papers fitted into the lids reduce, but do not prevent, dispersal. If plates are obviously wet, they should be opened in the Biological Safety Cabinet (13).

Less obvious is the release of aerosols when screw-capped bottles or plugged tubes are opened. This happens when a film of contaminated liquid, which may collect between the rim and the liner, is broken during removal of the closure (6). The practice of removing cotton plugs or other closures from flasks, bottles, centrifuge tubes, etc., immediately following shaking or centrifugation can generate aerosols and cause environmental contamination. The technique of shaking tissue cultures with glass beads to release viruses can create a virus-laden aerosol. Removal of wet closures, which can occur if the flask or centrifuge tube is not held in an upright position, is also hazardous. In addition, when using the centrifuge, there may be a small amount of foaming and the closures may become slightly moistened. Because of these possibilities, it is good safety practice to open all liquid cultures of infectious or hazardous material in a Biological Safety Cabinet wearing gloves and a long-sleeved laboratory garment.

Dried, infectious culture material may also collect at or near the rim or neck of culture tubes and may be dispersed into the air when disturbed (14). Containers of dry powdered hazardous materials should be opened only in a Biological Safety Cabinet (10,15).

When a sealed ampoule containing a lyophilized or liquid culture is opened, an aerosol may be created. Aerosol creation should be prevented or minimized, and opening of ampoules should be done in safety cabinets.

When recovering the contents of an ampoule, care should be taken not to cut the gloves or hands or disperse broken glass into the eyes, face, or laboratory environment. In addition, the biological product itself should not be contaminated with foreign organisms or with disinfectants. To accomplish this—work in a safety cabinet and wear gloves. Nick the ampoule with a file near the neck. Wrap the ampoule in disinfectant-wetted cotton. Snap the ampoule open at the nick, being sure to hold the ampoule upright. Alternatively, at the file mark on the neck of the ampoule, apply a hot wire or rod to develop a crack. Then, wrap the ampoule in disinfectant-wetted cotton, and snap it open. Discard cotton and ampoule tip into disinfectant. The contents of the ampoule are reconstituted by slowly adding fluid to avoid aerosolizing the dried material. Mix contents without bubbling, and withdraw it into a fresh container (13). Some researchers may desire to use commercially available ampoules prescored for easy opening. However, there is the possibility to consider that this may weaken the ampoule and cause it to break during handling and storage. Ampoules of liquid cultures are opened in a similar way.

Harvesting cultures from embryonated eggs is a hazardous procedure and leads to heavy surface contamination of the egg trays, shells, the environment, and the hands of the operator. It is essential that operations of this type be conducted in a Biological Safety Cabinet. A suitable disinfectant should be at hand and used frequently.

## 5. Centrifuging

Centrifugation presents two serious hazards: mechanical failure and dispersion of aerosols. A mechanical failure, such as a broken drive shaft, a faulty bearing, or a disintegrated rotor, can produce not only aerosols but also hazardous fragments moving at great velocity. These fragments, if they escape the protective bowl of the centrifuge, could produce traumatic injury to personnel. A well-functioning centrifuge, however, is still capable of producing hazardous aerosols of biological material or chemicals if improperly used or in the absence of good laboratory practices. Mechanical failure can be minimized by meticulous observance of the manufacturers' instructions, and aerosols can be avoided by observing sound laboratory practices and use of appropriate centrifuge safety equipment or Biological Safety Cabinets (16-23).

Although accidents from improper use of centrifuges and equipment associated therewith are far less frequent than with pipettes or syringes and needles, when they do occur aerosols usually are created, and the possibility of causing multiple exposures is considerably greater. This conclusion is borne out by data presented in the following table from the proceedings of a symposium held on centrifuge biohazards in 1973 (24).

INFECTION OR HYPERSENSITIVITY FROM CENTRIFUGING MICROBIAL MATERIAL

Disease	Comment	Persons Affected
Brucellosis	Aerosol spread from basement to 3rd floor	94
Glanders	Tube broke	3 (2 fatal)
Plague	Fluid spun off lip of intact centrifuge tube	1
Q fever	"Use of a centrifuge"	60
Q fever	Spread from 1st to 3rd floor*	47
Q fever	Throughout the building, "Centrifuging or grinding tissue"	15
Tuberculosis	Broken tube and a hole in trunnion cup	2
Tularemia	"Principally the pipetting and centrifugation"	1
Tularemia	Centrifuging	1
Western equine encephalitis	"Virus was thrown out"	1
Allergy attacks	Preparing antigens in a Sharples centrifuge	7
Allergy attacks	Killed <u>M. tuberculosis</u>	1

---

\*Waring blender used, and "high-speed centrifugation of formalinized suspensions and subsequent resuspension of sediments."

Activities, such as filling centrifuge tubes, removing cotton plugs and rubber caps from tubes after centrifugation, removing the supernatant and resuspending the cells, are capable of releasing aerosols into the environment. The greatest hazard associated with centrifuging biohazardous materials is created when a centrifuge tube breaks. When tubes break or crack and a fluid containing microorganisms remains in the cup under centrifugal force, relatively few organisms are released into the air compared to breakage that releases the fluid into the centrifuge chamber.

a. Safety Procedures Applicable to All Centrifuging

A safety centrifuge cabinet or safety centrifuge trunnion cup should be used when centrifuging hazardous or infectious substances. When bench-type centrifuges are used in a Biological Safety Cabinet, the glove panel should be in place with the gloves in place or with the ports covered. The centrifuge operation creates air currents that may cause the escape of agent from an open cabinet (17,27,28).

Centrifuge tubes and trunnion cups should be filled and opened in a Biological Safety Cabinet (29). If centrifugation is to be performed outside the cabinet, the safety trunnion cup should be used. After it is filled and sealed, it should be considered potentially contaminated and should be wiped with a cloth soaked in disinfectant or passed through a disinfectant dunk bath. Since some disinfectants are corrosive to centrifuge cups and heads, a rinse of the cup with clean water is desirable after an appropriate contact time has elapsed.

In some situations, in the absence of "O" ring sealed trunnion cup caps, specimens can be enclosed in sealed plastic bags before centrifugation (24). In the event of breakage, however, the plastic bag is likely to be ruptured. Thus, this technique normally only prevents the escape of organisms that contaminated the outside of the cup.

Before centrifuging, eliminate tubes with cracks and chipped rims, inspect the inside of the trunnion cup and correct rough walls caused by erosion or adhering matter, and carefully remove bits of glass and other debris from the rubber cushion (27,29).

A disinfectant should be added between the tube and trunnion cup to disinfect the materials in case of accidental breakage. This practice also provides an excellent cushion against shocks that might otherwise break the tube (27,29). Care must be taken, however, not to contaminate the culture material with the disinfectant. It must be recognized also that the disinfectant may not completely inactivate the infectious material when the tube breaks because of the dilution of the disinfectant and the high concentration and packing of cells.

Avoid pouring the supernatant material from centrifuge tubes. If you must do so, wipe off the outer rim with a disinfectant afterwards; otherwise, in a subsequent step, biohazardous fluid may be spun off as droplets that form an aerosol (27,29). Use of a vacuum system with appropriate in-line safety reservoirs and filters is preferable to pouring from centrifuge tubes or bottles.

If the sediment is packed infectious microorganisms or other hazardous material and must be resuspended in order to minimize the amount of aerosol created, it is better to use a swirling, rotary motion rather than shaking. If vigorous shaking is essential to suspend the material or achieve homogeneity, a few minutes should elapse before opening the container to allow the aerosol to settle. Shaking always contaminates the closure; thus, there is the added hazard of liquids dropping from the closure or running down the outside of the container. A Biological Safety Cabinet with gloves in place may be required to assure safety to the laboratory worker when performing some of these operations.

Avoid filling the centrifuge tube to the point that the rim, cap, or cotton plug becomes wet with culture (27,29).

Screw caps or caps that fit over the rim outside the centrifuge tube are safer than plug-in closures. Some fluid usually collects

between a plug-in closure and the rim of the tube. Even screw-capped bottles are not without risk, however; if the rim is soiled and sealed imperfectly, some fluid will escape down the outside of the tube (20).

Aluminum foil should not be used to cap centrifuge tubes containing toxic or infectious materials because these light-weight caps often become detached or ruptured during handling and centrifuging (20).

The balancing of buckets and trunnion cups is often improperly performed. Care must be taken to ensure that matched sets of trunnions, buckets and plastic inserts do not become mixed. If the components are not inscribed with their weights by the manufacturer, colored stains can be applied for identification to avoid confusion. When the tubes are balanced, the buckets, trunnions and inserts, including any disinfectant solution or water added for balancing, should be included in the procedure. The basic concern is that the centers of gravity of the tubes are equidistant from the axis of rotation. To illustrate the importance of this, two identical tubes containing 20 g of mercury and 20 g of water, respectively, will balance perfectly on the scales; however, their performance in motion is totally different, leading to violent vibration with all its attendant hazards (30).

#### b. Older Type and Small Portable Centrifuges

Older type centrifuges that do not have aerosol-tight chambers have been shown to allow the escape of aerosol created from various sources:

- biohazardous fluid remaining on the lip of the tube after decanting the supernatant fluid
- leakage from a tube in an angle-head centrifuge resulting from overfilling a tube and placing aslant in the centrifuge
- leakage from nonrigid tubes that distort under centrifugal forces, or
- fluid trapped in the threads of screw caps.

Safety trunnion cups should be used to prevent escape of aerosol in the event the primary culture container held in the cup should break or in any other manner allow the release of agent into the cup. The handling of the culture, the filling of centrifuge tubes and placing them in the safety trunnion cups should be done in a Biological Safety Cabinet. The outside of the trunnion cup should be decontaminated before the cup is removed for centrifuging. Subsequently, the cup should be returned to and opened in a Biological Safety Cabinet. Where applicable, the centrifuge itself should be placed in the cabinet, and, if need be, a cabinet should be specifically constructed for the centrifuge.

Small portable, "clinical" centrifuges have been shown to be hazardous (31). The microhematocrit centrifuge, in particular, has been shown to produce aerosols. A frequent practice is to centrifuge blood samples in tubes without closures or to use cotton plugs secured in the tubes by means of tape or pins. It should be recognized that some tissue specimens contain viable infectious microorganisms, particularly hepatitis virus, and that open tubes, contaminated closures, and release of aerosols from blood samples and tissue suspensions can be hazardous to laboratory personnel.

#### c. Sharples Centrifuges

Using the Sharples centrifuge with infectious or hazardous materials poses both engineering design and safety problems. The Sharples centrifuge is driven by a steam or air turbine, requires refrigeration around the bowl, and is equipped with feed and effluent lines. It has a continuous feed that could involve large volumes of liquid material, depending on the amount of solids in the material to be handled and the type of bowl. The centrifuge generates a massive aerosol that is almost impossible to contain within the instrument even with a hermetically sealed bowl (23). For these reasons, a ventilated safety cabinet is necessary to enclose the centrifuge. It may be desired to accommodate the material to be centrifuged and the effluent in the cabinet or handle it by means of connectors through the walls of the cabinet. If the rotor must be transferred to another cabinet



after use, it should be passed through a dunk bath, wrapped in a disinfectant-soaked towel, or placed in another container, the outside of which is decontaminated. Decontamination of the centrifuge bowl, lines, and surrounding cabinet can be accomplished by liquid disinfectants, formaldehyde vapor or ethylene oxide, followed by additional cleaning and rinsing. The rotor can be steam sterilized.

d. High-Speed Centrifuges

Centrifugation at high speeds presents additional hazards because of the higher stresses and forces applied to components of the system. In addition to the recommended practices listed above, precautions should be taken to filter the air exhausted from the vacuum lines, to avoid metal fatigue resulting in disintegration of rotors, and to apply proper techniques in cleaning, handling, and using centrifuge components. Some of these precautions are discussed briefly below.

In high-speed centrifuges, the chamber is connected to a vacuum pump. If there is a breakage or accidental dispersion of infected particles, the pump and the oil in it will become contaminated. A HEPA filter should be placed between the centrifuge and the pump (20).

High-speed rotor heads are prone to metal fatigue, and, where there is a chance that they may be used on more than one machine, each rotor should be accompanied by its own log book indicating the number of hours run at top or de-rated speeds. Failure to observe this precaution can result in dangerous and expensive disintegration. Frequent inspection, cleaning, and drying are important to ensure absence of corrosion or other damage that may lead to the development of cracks. If the rotor is treated with a disinfectant, it should be rinsed with clean water and dried as soon as the disinfectant has adequately decontaminated the rotor. Rubber "O" rings and tube closures must be examined for deterioration and be kept lubricated with the material recommended by the makers. Where tubes of different materials are provided (e.g., celluloid, polypropylene, stainless steel), care must be taken that the tube closures designed specifically for the type of tube in use are employed. These caps are often similar in

appearance, but are prone to leakage if applied to tubes of the wrong material. When properly designed tubes and rotors are well maintained and handled, leaking should never occur (30).

Cleaning and disinfection of tubes, rotors and other components require considerable care. It is unfortunate that no single process is suitable for all items, and the various manufacturers' recommendations must be followed meticulously if fatigue, distortion and corrosion are to be avoided. This is not the place to catalogue recommended methods, but one less well appreciated fact is worthy of mention. Celluloid (cellulose nitrate) centrifuge tubes are not only highly flammable and prone to shrinkage with age and distortion on boiling, but also can be highly explosive in an autoclave (30).

e. Large-Scale Zonal Centrifuges

Zonal centrifuges have been developed to process relatively large volumes, 5 to 150 liters, of material. The pumps, valves, seals, feed lines, connectors, and vacuum and cooling systems, associated with these centrifuges, as well as the large volumes processed at high speeds, create the potential for leakage and generation of hazardous aerosols leading to the contamination both of the environment and of the operating personnel. The following areas have been identified as the principal sources of potential leakage: the centrifuge lip and face seals, the coolant system, the turbine exhaust air, various lines and connectors, the feed system, fraction collection, and during decontamination. In addition, the possibility of spills occurring during loading, unloading, sample collection, decontamination, and other procedures must be recognized (32,33).

The several seals in the equipment pose the greatest potential for escape of hazardous material because inherent to the system is the necessity for pressurizing the process fluid to obtain flow through the rotor; in addition, leaks may occur because of the large centrifugal forces exerted at all points in the rotating component. Procedural hazards identified include: (a) the danger of snagging or rupturing one of the numerous lines (influent, effluent, rotor by-pass, etc.), particularly when

hemostats are used as clamps; (b) undetected over-pressurization of lines resulting in a rupture of a line or failure of a connection because flow was obstructed by bubbles caught in the system; (c) manual making and breaking of connections during the centrifuge operation; (d) inadequate precautions in handling gradient fractions containing very high concentrations of the purified material; and (e) incomplete or ineffective decontamination procedures of the rotor, feed lines and other components of the equipment before disassembly and cleanup (34-36).

Zonal centrifuges that employ B rotor systems can be readily adapted under Class I cabinets. Some laboratories have attached a fume hood onto the centrifuge and have installed a HEPA filter in the exhaust duct from the hood. This type of arrangement permits utilization of the hood for most activities associated with the centrifugation process. It is suggested that a sink be installed in the hood or a container be available adjacent to the centrifuge for dunk decontamination of the rotor.

Users of these centrifuges feel that the potential hazards can be decreased by designing more dependable lip seals and face seals, by designing a biologically tight coolant system with provisions for adding fresh glycol and withdrawing contaminated coolant in a closed system, and by making the control console switches more versatile, such as the addition of switches to permit coolant flow without the need of having to turn on the vacuum for the post-run flushing to the coolant system.

Today, many laboratories are using the batch or continuous flow zonal type ultracentrifuge. Since each installation may be somewhat different, it may be necessary to determine initially, using a biological simulant, whether leakage occurs and whether there is aerosolization of fluid into the room. In addition, it is advisable to examine the equipment carefully to judge which parts are most likely to leak and take protective measures, if possible. For example, routine part changes and inspections should be done to minimize faulty components with the K-II continuous sample flow zonal centrifuge (28), namely: (a) change top lip seal after each run, (b) change bottom lip seal after three runs, (c) inspect face seal after

each run, (d) change rotor end cap "O" rings after each run, and (e) check rotor spindle pivots after each run to assure a smooth-running rotor. The catcher-slinger drain container should contain iodophor equal to 2% when the container is full, and the coolant reservoir level is checked regularly to determine if seal leakage is occurring.

The following safety precautions should be observed when using large-scale zonal centrifuges:

- The centrifuge normally should be placed in a Biological Safety Cabinet under negative pressure when using hazardous agents. For high risk agents, the centrifuge and satellite apparatus should be contained in a Class III cabinet system. An alternative to the cabinet is a small negative pressure room with a leak-tight door for maintenance access. The centrifuge in this small room could be operated remotely or through glove ports.

- The exhaust air from the containment room or safety cabinet should be filtered with HEPA filters.

- The exhaust air from the turbine drive should be passed through HEPA filters before being released to the atmosphere. Installation of a trap to remove oil mist from this exhaust air markedly extends the life expectancy of the filters. Vacuum pump exhaust air should be similarly filtered before release.

- Although some manufacturers recommend that the catcher-slinger fluid collections be purged through the turbine exhaust, there is an advantage in draining the collections to the exterior of the assembly. The discharge from the drain orifice, both air and fluid, must be contained; a disinfectant-containing transparent receiver with a filtered vent is recommended. A similar trap and venting arrangement should be used on the rotor bypass lines for removing bubbles from the fluid feed lines.

- Process feed lines, especially those under positive pressure, should be kept as short as possible and have as few connections as possible. Utilization of 3-, 4-, and 5-way valves is suggested to facilitate the consolidation of the many lines in the system. A panel consisting of pump, flow meter, pressure gage, valves and stainless steel fluid lines, to which influent and effluent lines are attached, is suggested. For all external flexible lines, tygon tubing with a minimum of 1/16" wall thickness and polypropylene connectors having positive, strong fasteners are suggested. Additional safety is provided by nylon strap hose clamps on slip fittings. Operating pressure on feed lines should not exceed 15 psig. A pressure gage and flow meter should be mounted in the line between

the pump and the split to the top and bottom rotor feed lines. An added safety factor would be the provision of an audible alarm to the pressure gage. If possible, the feed line system should be pressure tested before introduction of biohazardous fluids. Testing is usually performed at the time the face seals are leak tested by filling the system with sterile buffer solution or water and the air is purged from the rotor.

- A peristaltic pump is recommended for energizing the flow of process fluids to the rotor. Although line pressure can be automatically regulated to a preset limit at the air pressure source, the pump method is recommended because it places only the line between pump and rotor under pressure. Because some pumps use soft rubber tubing, ballooning and rupture are possible; this tubing should be replaced frequently. It is recommended that the peristaltic pump, and as many of the lines as possible, be contained in a primary barrier.

- Gradient fractions should be collected within the confines of a primary barrier. A Class I or Class II cabinet is recommended. For high risk agents, a Class III cabinet should be used. An alternative is to perform the fraction collection within a plastic glove bag or box prefitted with the gradient discharge tubing running into it. After the fractions are collected, the entire bag and contents are removed to a safety cabinet for subsequent manipulation.

- The total system, including feed lines, effluent lines, coolant system, and ancillary equipment that may have contained or been exposed to hazardous agents, should be decontaminated prior to any breaking of lines or disassembly of the centrifuge. Gradient residue should be flushed from the rotor and core with warm water before the disinfectant is introduced. The rotor should be filled and flow reversed several times to assure contact of the disinfectant with all surfaces. Surface decontamination of the rotor exterior and shafts is suggested as it is raised from the rotor chamber. The end caps should be loosened and the rotor and core completely immersed in a disinfectant solution for initial cleaning. Special precautions should be taken against accumulations of debris in the shoulders of the end caps that the internal disinfectant may not have reached. All lines, influent bottles, reservoirs, connectors, etc., must be autoclaved before cleaning for reuse or discarding. For high risk agents, the decontamination with disinfectant should be followed by ethylene oxide exposure overnight at 60% relative humidity and 80°F for the entire cabinet and its contents. Ethylene oxide access to the rotor chamber and turbine air drive lines should be provided. After the centrifuge and external equipment (lines, pump, valves, etc.) have been cleaned, reassembled, leak tested, and are ready for the next lot of material, they must be sterilized. For virus work, 70% ethanol is recommended; flow must be reversed several times and all bubbles removed to assure contact of the alcohol with all surfaces. The ethanol is drained and flushed out with sterile distilled water to minimize the possibility of residual concentrations that would

affect the virus. For bacterial and other organisms, particularly those that produce spores, alcohol may not be a suitable disinfectant. Regardless of what disinfectant is used, however, the system should be flushed out with sterile distilled water. In some instances, it may be necessary to flush the system with a sterile specific neutralizer for the disinfectant prior to the final flushing with sterile distilled water.

- Protective clothing, including a respirator, should be worn in areas where there is possible exposure to hazardous or infectious materials.

- No material should be removed from the special centrifuge room or Biological Safety Cabinet unless it has been decontaminated.

- The operator should be thoroughly familiar with this equipment to identify problem areas and to establish a system of replacing components likely to result in leakage.

## 6. Blenders, Mixers, Sonicators, and Cell Disruption Equipment

Hazardous aerosols are created by most laboratory operations concerned with blending, mixing, stirring, grinding or disrupting materials such as cells, tissues, blood samples, freeze-dried sera, and environmental samples that may contain infectious, toxic or otherwise hazardous materials. Even use of the mortar and pestle can be a hazardous operation. Ball mills, colloid mills, jet mills, tissue grinders, magnetic mixers, stirrers, sonic cleaning devices, ultrasonic cell disintegrators, and shakers are other devices that can produce hazardous aerosols.

### a. Blenders and Mixers

The hazards associated with the liberation of aerosols during the operation of the blender have been recognized for many years. In one investigation (37), the air was sampled during the operation of two types of blenders; one was a one-liter plastic-capped bowl, the other was a 500 ml screw-capped bowl. The results, shown below, are indicative of the hazardous nature of aerosol release from a standard blender and also show how rapidly the aerosol decays within the blender.

#### Serratia indica recovered from aerosols produced during the operation of a blender

	<u>Serratia indica</u> recovered*	
	Plastic cap	Screw cap
During 2-minute operation	511	18
Cap removed immediately after blender was turned off	>2,100	>2,100
Cap removed 5 minutes after blender was turned off	306	629
Cap removed 90 minutes after blender was turned off	50	40

\*Numbers refer to colonies appearing on sieve sampler plates. Sampling was at the rate of 1 cu. ft. per min. for 2 min. during blending, and for 3 min. following the operation. When the cap was removed, it was replaced after 10 sec.

Investigations were conducted on the particle size distribution of S. marcescens aerosols created during common laboratory procedures and simulated laboratory accidents (38). Over 1,600 viable particles per cubic foot of air sampled were recovered during blending operations and more than 93% of these particles were less than five microns in size. It was demonstrated that removal of the blender top immediately following the blending operation produced an aerosol with a mean concentration of 1,500 viable particles per cubic foot of air sampled.

The potential for accidental microbial aerosol transmission in the biological laboratory was discussed in 1973 at the Conference of Biohazards in Cancer Research held at the Asilomar Conference Center, Pacific Grove, California; it was reported that blenders and homogenizers are particularly dangerous (39). It was recommended that these devices be used in a hood or other container that can be properly ventilated if the material is suspected of being pathogenic or allergenic. It was stressed that a gastight cabinet *must be used in the event the material is highly pathogenic.*

High-speed blenders for safely processing infectious materials have been proposed. The unique features of one blender include (i) the elimination of gaskets and bearings at the bottom of the blender bowl by placing the bearings and drive motor at the top, outside the bowl, (ii) the provision for cooling the drive shaft and bearings with dry ice, (iii) the inclusion of a rubber washer in the lid, which is screwed onto the cup, and (iv) the fabrication of the bowl and lid from stainless steel. An air inlet and drainpipe are provided to allow for the removal of the contents without opening the lid, which would release an aerosol. This equipment is not commercially available; however, sufficient detail for fabrication has been published (40). Other studies (41,42) concerned the infection hazards of the high-speed blender and presented means of correcting the problem by utilization of a new blender design. As an outgrowth of these studies, a safety container (Waring AS-1) for the Waring blender is commercially available that can be autoclaved or otherwise sterilized, has biologically inert teflon bearings, a "standpipe"



agitator, a leak proof lid with an "O" ring gasket secured by swivel thumbscrews, and outlet fittings to allow the continuous flow of the ingredients. The lid also has an outlet plug to permit easy removal of samples, as shown in the following figure.

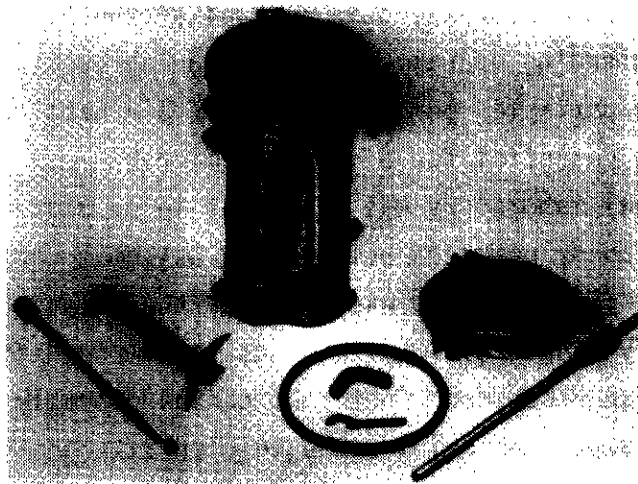

**CONTAINER (WARING AS-1) FOR THE SAFE BLENDING  
OF HAZARDOUS MATERIALS**

Magnetic mixers, although generally operated at slower speeds than blenders and not designed to create a turbulent, macerating action, are capable of creating aerosols, particularly if the material mixed produces bubbles or foam. Magnetic mixers provide a comparatively gentle, swirling action, but the mixing of infectious, oncogenic, allergenic, or toxic materials should be considered a potentially hazardous operation. Thus, the same safety concerns apply to magnetic mixers as to blenders.

b. Sonicators

Aerosol hazards associated with the operation of an ultrasonic oscillator have been reported (43,44). Particles of infectious or hazardous materials can escape because of loosely fitting covers, loose gaskets at the bottom of the cup, or when the contents are removed from the cup. Use of a larger size "O" ring was found to provide a satisfactory closure. Modification of the cover to permit installation of a rubber diaphragm provided means for the safer removal of the contents by a syringe and needle. It also was recommended that sonicators be used in Biological Safety Cabinets.

Adequate decontamination of equipment potentially contaminated with infectious material prior to sonic cleaning is essential because of the hazard of creating aerosols during the sonic treatment (45). Wherever sonicators are used in a cleaning process, such as in dishwashers, animal cage washers, etc., all items should be sterilized prior to cleaning.

c. Recommended Practices

Safe laboratory practices that are required generally when using blenders, mixers, ultrasonic disintegrators, colloid mills, jet mills, grinders, and mortars and pestles with hazardous biological or chemical materials are as follows:

- Operate blending and cell disruption and grinding equipment in a Biological Safety Cabinet.
- Use safety blenders designed to prevent leakage from the rotor bearing at the bottom of the bowl. In the absence of a leakproof rotor, inspect the rotor bearing at the bottom of the blender bowl for

leakage prior to operation. Test it in a preliminary run with sterile water, saline or methylene blue solution prior to use.

- If the blender is used with infectious material, use a towel moistened with disinfectant over the top of the blender. Sterilize the device and residual contents promptly after use.

- Glass blender bowls are undesirable for use with infectious material because of potential breakage. If used, they should be covered with a propylene jar to prevent dispersal of glass in the event the bowl breaks.

- A heat-sealed flexible disposable plastic film enclosure can be used for a grinder or blender. The safest practice is to use these within a Biological Safety Cabinet. That means they are not used for total containment but rather to spare gross contamination of the cabinet when equipment or procedures are used that are known to release aerosols.

- Blender bowls sometimes require supplemental cooling to prevent destruction of the bearings and to minimize thermal effects on the product.

- Before opening the safety blender bowl, permit the blender to rest for at least one minute to allow settling of the aerosol cloud.

## 7. Miscellaneous Precautions and Recommendations

Water baths and Warburg baths used to inactivate, incubate, or test infectious substances should contain a disinfectant. For cold water baths, 70% propylene glycol is recommended (29,46). Sodium azide should not be used as a bacteriostatic. It creates a serious explosion hazard.

Deepfreeze, liquid nitrogen, and dry ice chests and refrigerators should be checked and cleaned out periodically to remove any broken ampoules, tubes, etc., containing infectious material, and decontaminated. Use rubber gloves and respiratory protection during this cleaning. All infectious or toxic material stored in refrigerators or deepfreezers should be properly labelled. Security measures should be commensurate with the hazards (29,46,47). The degree of hazard represented by contaminated liquid nitrogen reservoirs will be largely dependent upon the infectious potential of the stored microorganisms, their stability in liquid nitrogen, and their ability to survive in the airborne state. Investigations suggest that storing tissue culture cell lines in containers other than sealed glass ampoules might result in potential intercontamination among cell lines stored in a common liquid nitrogen repository.

It must be recognized that evacuating the atmosphere from a vacuum steam sterilizer prior to sterilization of contaminated material potentially can create a hazard by releasing infectious material to the atmosphere. This hazard can be prevented by installation of an efficient in-line HEPA filter (water resistant; e.g., Flanders 7C81R-G) (48).

Ensure that all hazardous fluid cultures or viable powdered infectious materials in glass vessels are transported, incubated, and stored in easily handled, nonbreakable leakproof containers that are large enough to contain all the fluid or powder in case of leakage or breakage of the glass vessel (29,46).

All inoculated petri plates or other inoculated solid media should be transported and incubated in leakproof pans or leakproof containers (29,46).

Care must be exercised in the use of membrane filters to obtain

sterile filtrates of infectious materials. Because of the fragility of the membrane and other factors, such filtrates cannot be handled as non-infectious until culture or other tests have proved their sterility (29,46).

Shaking machines should be examined carefully for potential breakage of flasks or other containers being shaken. Screw-capped durable plastic or heavy walled glass flasks should be used. These should be securely fastened to the shaker platform. An additional precaution would be to enclose the flask in a plastic bag with or without an absorbent material.

No person should work alone on an extremely hazardous operation (29,46).

## REFERENCES

1. Pike, R.M. 1976. Laboratory-associated infections: Summary and analysis of 3,921 cases. *Health Lab Sci* 13:105-114.
2. Dimmick, R.L., W.F. Vogl, and M.A. Chatigny. 1973. Potentials for accidental microbial aerosol transmission in the biological laboratory. Pages 246-266 in A. Hellman, M.N. Oxman, and R. Pollack, eds. *Bio-hazards in biological research*. Cold Spring Harbor Laboratory, NY.
3. Wedum, A.G., W.E. Barkley, and A. Hellman. 1972. Handling of infectious agents. *J Am Vet Med Assn* 161:1557-1567.
4. Wedum, A.G. 1964. Laboratory safety in research with infectious aerosols. *Pub Health Rpts* 79:619-633.
5. Phillips, G.B., and J.V. Jemski. 1963. Biological safety in the animal laboratory. *Lab Animal Care* 13:13-20.
6. American Conference of Governmental Industrial Hygienists. 1977. *Threshold Limit Values for Chemical Substances in Workroom Air*. P.O. Box 1937, Cincinnati, OH 45201.
7. U.S. Department of Health, Education, and Welfare, National Cancer Institute, Office of Research Safety. 1974. *Safety standards for research involving oncogenic viruses*. Bethesda, MD 20014. DHEW Publication No. (NIH) 78-790.
8. Anon. 1968. *Good Laboratory Practices Manual*. National Cancer Institute, Bethesda, MD.
9. Reitman, M., M.L. Moss, J.B. Harstad, R.L. Alg, and N.H. Gross. 1954. Potential infectious hazards of laboratory techniques. I. Lyophilization; II. The handling of lyophilized cultures. *J Bact* 68:541-548.
10. Phillips, G.B. 1965. Microbiological hazards in the laboratory. *J Chem Education*. Part One - Control, 42:A43-A48. Part Two - Prevention, 42:A117-A130.
11. Chatigny, M.A., and D.I. Clinger. 1969. Contamination control in microbiology. In R.L. Dimmick and A.B. Akers (eds.). *An Introduction to Experimental Aerobiology*. John Wiley & Sons, New York, pp. 194-263.
12. Hanel, E., and R.H. Kruse. 1967. Laboratory-acquired mycoses. *Misc. Publ.* 28. AD-665376. Frederick Cancer Research Center, P.O. Box B, Frederick, MD.

13. Harney, R.W.S., T.H. Price, and D.H.M. Joynson. 1976. Observations on environmental contamination in a microbiological laboratory. *J Hyg Camb* 76:91-96.
14. Collins, C.H., E.G. Hartley, and R. Pilsworth. 1974. The prevention of laboratory-acquired infection. Public Health Laboratory Service Monograph Series No. 6. Her Majesty's Stationery Office, London.
15. Grieff, D. 1969. Safe procedure for opening evacuated glass ampoules containing dried pathogens. *Appl Microbiol* 18:130.
16. Reitman, M., and A.G. Wedum. 1966. Microbiological safety. *Public Health Rep* 71:659-665.
17. Wedum, A.G. 1964. Laboratory safety in research with infectious aerosols. *Pub Health Rep* 79:619-633.
18. Phillips, G.B. 1965. Microbiological hazards in the laboratory. *J Chem Education*. Part One-Control 42:A43-A48. Part Two - Prevention 42:A117-A130.
19. Chatigny, M. 1961. Protection against infections in the microbiological laboratory devices and procedures. In W.W. Umbreit (ed.). *Advances in Applied Microbiology* No. 3. Academic Press, New York, pp. 131-192.
20. Collins, C.H., E.G. Harley, and R. Pilsworth. 1974. The prevention of laboratory-acquired infection. Public Health Laboratory Service Monograph Series No. 6. Her Majesty's Stationery Office, London.
21. Reitman, M., and A.G. Wedum. 1966. Microbiological safety. *Pub Health Rep* 71:659-665.
22. Reitman, M., and G.B. Phillips. 1956. Biological hazards of common laboratory procedures III. The centrifuge. *Am J Med Tech* 22: 14-16.
23. Evans, C.G.T., R. Harris-Smith, J.E.D. Stratton, and J. Melling. 1974. Design and construction of a ventilated cabinet for a continuous flow centrifuge. *Biotech and Bioeng* 16:1681-1687.
24. Morris, C.A., and P.H. Everall. 1972. Safe disposal of air discharged from centrifuges. *J Clin Path* 25:742.
25. Wedum, A.G. 1973. Microbiological centrifuging hazards. In *Centrifuge Biohazards, Proceedings of a Cancer Research Safety Symposium*, Frederick Cancer Research Center, Frederick, MD., Nov. 8.
26. Pike, R.M. 1976. Laboratory-associated infections: Summary and analysis of 3,921 cases. *Health Lab Sci* 13:105-114.

27. Hellman, A. 1969. Biohazard control and containment in oncogenic virus research. USPHS, NIH, NCI.
28. Hall, C.V. 1975. A biological safety centrifuge. *Health Lab Sci* 12:104-106.
29. U.S. Public Health Service. 1974. NIH Biohazards Safety Guide. GPO Stock #174000383. Supt Documents, U.S. Government Printing Office, Washington, DC. 20402. (\$3.85)
30. Darlow, H.M. 1969. Safety in the microbiological laboratory. In J.R. Norris and D.W. Ribbons (eds.). *Methods in Microbiology*. Academic Press, New York, pp. 169-204.
31. Rutter, D.A., and C.G.T. Evans. 1972. Aerosol hazards from some clinical laboratory apparatus. *Brit Med J* 1:594-597.
32. Toplin, I. 1973. Tumor virus purification using zonal rotors: A review with emphasis on biohazardous operations. In *Centrifuge Biohazards. Proceedings of a Cancer Research Safety Symposium*, Frederick Cancer Research Center, Frederick, MD., pp. 17-32.
33. Lemp, J.F., Jr., and C.T. Rankin, Jr. 1973. E. coli phage assessment of biohazard associated with oncogenic virus purification in large, high-speed centrifuges. *Ibid*, pp. 33-59.
34. Baldwin, C.L., J.F. Lemp, and M.S. Barbeito. 1975. Biohazards assessment in large-scale zonal centrifugation. *Appl Microbiol* 29:484-490.
35. Baldwin, C.L. 1973. Biological safety recommendations for large-scale zonal centrifugation of oncogenic viruses. In *Centrifuge Biohazards. Proceedings of a Cancer Research Safety Symposium*, Frederick Cancer Research Center, Frederick, MD., pp. 61-71.
36. Henke, C.B. 1973. Containment recommendations and prototype equipment for ultracentrifuges in cancer research. *Ibid*, pp. 111-136.
37. Anderson, R.E., L. Stein, M.L. Moss, and N.H. Gross. 1952. Potential infectious hazards of common laboratory techniques. *J Bact* 64:473-481.
38. Chatigny, M. 1961. Protection against infection in the microbiological laboratory, devices and procedures. In W.W. Umbreit (ed.), *Advances in Applied Microbiology* No. 3. Academic Press, New York, pp. 131-192.
39. Kenny, M.T., and F.L. Sabel. 1968. Particle size distribution of Serratia marcescens aerosols created during common laboratory procedures and simulated laboratory accidents. *Appl Microbiol* 16:1146-1150.



40. Chatigny, M.A., W.E. Barkley, and W.A. Vogl. 1974. Aerosol biohazard in microbiological laboratories and how it is affected by air conditioning systems. *Am Soc Heat Refrig Air Cond Eng* 80:463-469.
41. Hilleman, M.R., and R.O. Taylor. 1958. A safe high-speed blender for processing infectious materials. *J Lab Clin Med* 51:977-980.
42. Reitman, M., M.A. Frank, Sr., R. Alg, and A.G. Wedum. 1953. Infectious hazards of the high-speed blender and their elimination by a new design. *Appl Microbiol* 1:14-17.
43. Sulkin, S.E., and R.L. Pike. 1951. Survey of laboratory-acquired infections. *Am J Pub Health* 41:769-781.
44. Sperber, W. 1976. Sterile preparation of bact: samples without equipment cleanup. *Food Processing*. Sept.
45. Reitman, M., and A.G. Wedum. 1956. Microbiological safety. *Pub Health Rpts* 71:659-665.
46. Hellman, A. 1969. Biohazard control and containment in oncogenic virus research. USPHS, NIH, NCI.
47. Godber, G. 1975. Report of the working party on the laboratory use of dangerous pathogens. Cmnd 6054, ISBN 0 10 160540, 40 pp. Her Majesty's Stationery Office, London.
48. Barbeito, M.S., and E.A. Brookey, Jr. 1976. Microbiological hazard from the exhaust of a high-vacuum sterilizer. *Appl Env Microbiol* 32:671-678.

## B. Personal Hygiene Habits and Practices

Personal hygienic practices in the laboratory are directed, in most part, toward the prevention of occupationally acquired physical injury or disease. To a less obvious extent, they can raise the quality of the laboratory work by reducing the possibilities for contamination of experimental materials. The reasons for many of the recommended precautions and practices are obvious, but, in some instances, amplification will permit a better review of the applicability to any one specific laboratory. Consequently, what might be forbidden in one laboratory might be only discouraged in another and be permissible in a third. Nevertheless, adherence to safe practices that become habitual, even when seemingly not essential, provides a margin of safety in situations where the hazard is unrecognized. The history of occupational injury is replete with examples of hazards unrecognized until too late. The following guidelines, recommendations, and comments are presented with this in mind:

- Food, candy, gum, and beverages for human consumption should be stored and consumed only outside the laboratory.
- Foot-operated drinking fountains should be the sole source of water for drinking by human occupants of the laboratory (1).\* These should be located in the corridor, not the laboratory. The water line that serves the laboratory faucets should be separated from the water line to the drinking fountain by appropriate devices that prevent back-flow.
- Smoking is not permitted in the laboratory or animal quarters. Cigarettes, pipes, and tobacco should be kept only in clean areas designated for smoking (2,3,4).
- Shaving and brushing of teeth should not be permitted in the laboratory. Razors, toothbrushes, toiletry supplies, and cosmetics are permissible in clean change rooms or other clean areas, but should never be used until after showering or thorough washing of the face and hands.
- A beard may be undesirable in the laboratory in the presence of actual or potential airborne contamination because it retains particulate contamination more persistently than clean-shaven skin. A clean-shaven face is essential to the adequate fit of a face mask or respirator when the work requires respiratory protection (1,3).

\*The references for this section appear on page 45.

- Keeping hands away from mouth, nose, eyes, face, and hair should become habit. This may prevent self-inoculation (1,3).

- For product protection, persons with long hair should wear a clean hair net or head cover. This has long been a requirement in hospital operating rooms and in the manufacture of biological pharmaceutical products. A head cover also will protect the hair from fluid splashes, from swinging into Bunsen flames and petri dishes, and will reduce facial contamination caused by frequent rearrangement of the hair to move it off the face (3).

- Long-flowing hair and loose-flapping clothing are dangerous in the presence of open flame or moving machinery. Rings, wrist watches, and other jewelry also are physical hazards during the operation of some types of machines (2,3).

- Personal items, such as coats, hats, storm rubbers or overshoes, umbrellas, purses, etc., should not be kept in the laboratory (5).

- Books and journals returnable to the institutional library should be used only in the clean areas as much as possible. Under no circumstances should books or journals on loan from institutional libraries be taken into a P4 facility (29,42).

- Personal cloth handkerchiefs should not be used in the laboratory. Cleansing tissue should be available in laboratories and change rooms.

- Hand washing should be done promptly after removing protective gloves. Tests show it is not unusual for microbial or chemical contamination to be present despite use of gloves, due to unrecognized small holes, abrasions, tears, entry at the wrist, or solvent penetration through the gloves.

- Hands should be washed after removing soiled protective clothing, before leaving the laboratory area, before eating, before smoking, and throughout the day at intervals dictated by the nature of the work. Jewelry should not be worn in the laboratory as it will interfere with the hand washing procedure. If worn, it could become contaminated and cause the contamination to be brought to the home (6,39,43,45).

- A disinfectant wash or dip may be desirable in some cases, but its use must not be carried to the point of causing roughening, desiccation or sensitization of the skin (6,39,43).

- Work should not be done with biohazardous materials by anyone with a fresh or healing cut, abrasion, a lesion of the skin or any open wound, including that resulting from a tooth extraction (6,45).

## REFERENCES

1. U.S. Army. 1969. Safety regulations, microbiological, chemical and industrial safety. FDR 385-1. Fort Detrick, Frederick, MD.
2. U.S. Public Health Service. 1974. NIH Biohazards Safety Guide. GPO Stock #1740-00383. Supt Documents, U.S. Government Printing Office, Washington, DC. 20402. (\$3.85)
3. Barbeito, M.S., C.T. Mathews, and L.A. Taylor. 1967. Microbiological laboratory hazard of bearded men. *Appl Microbiol* 15:899-906.
4. Darlow, H.M. 1969. Safety in the microbiological laboratory. In J.R. Norris and D.W. Ribbons (eds.). *Methods in Microbiology*. Academic Press, New York, pp. 169-204.
5. U.S. Public Health Service. 1975. Lab safety at the Center for Disease Control. DHEW Publication No. CDC 76-8118. USPHS, CDC, Atlanta, GA.
6. Lennette, E.H., et al. 1974. Laboratory safety regulations, viral and rickettsial disease laboratory. California State Department of Health, Berkeley, CA.
7. Collins, C.H., E.G. Hartley, and R. Pilsworth. 1974. The prevention of laboratory-acquired infection. Public Health Laboratory Service Monograph Series No. 6. Her Majesty's Stationery Office, London.

### C. Protective Clothing and Equipment

Protective clothing and equipment are used to protect the laboratory worker from contact with infectious, toxic and corrosive agents, excessive heat, fire, and other physical hazards. Also, suitable clothing and equipment can help protect the experiment itself from contamination. The extent and kinds of clothing and equipment to be selected for any particular activity are dependent upon the research operations and the levels of potential hazard associated with them. While clothing and personnel safety equipment are of importance in an overall biological safety program, they are to be used with the understanding that they serve as a secondary line of defense. Biological Safety Cabinets accompanied by good laboratory techniques and procedures are the primary barriers against potential exposure to hazardous materials.

Certain types of laboratory clothing and protective equipment are safer, more practical, and provide greater comfort than others. Comfort, however, must not be the overriding factor in the final selection of an item required for protection. Once proper protective clothing and equipment are selected, it is the task of the supervisor to provide training in their use and to assure that employees properly use and maintain them.

The applications of these various items of protective clothing and equipment in the conduct of recombinant DNA research are summarized in the table on the following page.

**SUMMARY OF MINIMUM REQUIREMENTS REGARDING LABORATORY ISSUED  
PROTECTIVE CLOTHING AND EQUIPMENT FOR RECOMBINANT DNA RESEARCH**

Physical Containment Level	Protection Required				
	Hand	Head	Body	Foot	Respiratory
P1			The use of laboratory gowns, coats or uniforms is at the discretion of the laboratory supervisor.		
P2			The use of laboratory gowns, coats or uniforms is required. Laboratory clothing shall not be worn to the lunchroom or outside the building in which the laboratory is located.		
P3	Gloves shall be worn when handling materials requiring P3 containment. They shall be removed aseptically immediately after use and decontaminated.		Laboratory clothing that protects street clothing (i.e., long-sleeve, solid-front or wrap-around gowns, no-button or slip-over jackets, etc.) shall be worn in the laboratory. Front button laboratory coats are unsuitable. Laboratory clothing shall not be worn outside the laboratory and shall be decontaminated before it is sent to the laundry.		Respiratory protection is required for emergency procedures.
P4	Gloves shall be worn when conducting procedures requiring P4 containment.	Headcover is required. Headcover is not to be worn outside the work area.	Complete laboratory clothing, including undergarments, pants and shirts, or jumpsuits, shall be provided and worn in the P4 facility. Laboratory clothing shall not be worn outside the P4 facility.	Laboratory-issued shoes are required. These are not to be worn outside the work area.	Respiratory protection is required for emergency procedures.

For P4 suit room conditions, all personnel are required to wear one-piece positive pressure suits.

The specifics of protective clothing and equipment are included in the following discussions; however, a broader treatment of the overall field can be found in the Accident Prevention Manual for Industrial Operations, Chapter 19, "Personal Protective Equipment," prepared by the National Safety Council, pages 465-527, 7th edition, dated 1974.

## 1. Laboratory Clothing

Laboratory clothing can serve to protect the wearer, the experiment, and the environment against contamination. The user must wear the garments in the manner intended to assure the benefits of the protection they can provide. If proper precautions are not taken, clothing may carry microbiological contamination outside the laboratory and into other work areas, cafeterias, or the home. Microorganisms can remain viable on cotton and wool fabrics and can be disseminated from these fabrics.

The National Institutes of Health Recombinant DNA Guidelines include requirements for the use of protective clothing and equipment at the P2, P3 and P4 physical containment levels. For P1 containment, the use of laboratory clothing is left to the discretion of the project supervisor. However, if good microbiological practices are to be applied to protecting the integrity of the experiment, the general and effective use of laboratory clothing should be encouraged.

Local clothing requirements above the minimum required by the Guidelines will vary from one institution to another. Many institutions recommend that animal handlers and technical operations personnel be provided a complete clean clothing change on a daily basis. While a full-length and fully fastened laboratory coat worn over street clothing may be acceptable in some cases, laboratories have found that, for reasons of comfort, mobility and enhanced protection, one- or two-piece laboratory suits, solid-front gowns, and wraparound smocks are preferable. Long-sleeved garments are best for protection of the arms and to minimize shedding of contaminating microorganisms from them. For the same reasons, consideration should be given to the need for a head covering (cap or head hood) and a snug-fitting collar at the neck. The garments usually have close-fitting closures: knitted cuffs, snaps, drawstrings or elastic circlets. Drawstrings for men's pantwaist closures and adjustable snap-type waist closures for women seem to be preferred. Some of the available styles of laboratory clothing are shown in the illustrations later in the Section.

Clothing inventory planning should provide for the needs of visitors



and of maintenance and security personnel. For some P1, P2 and P3 facilities, scientists who visit on a short-term basis may find long-sleeved wraparound disposable smocks to be versatile in that they give good protection over street clothes and accommodate a range of sizes. Other laboratories use disposable jumpsuits. These types also are used for the short visits that maintenance staff and security guards make for routine visits in off-duty hours to check that equipment is performing satisfactorily. When extensive maintenance work is involved, the personnel may require sturdier, reusable garments.

Laboratory-issued clothing should not be worn outside the facility or to the library, cafeteria, or other places accessible to the public. For P3 and P4 facilities, the use of specially colored laboratory clothing is recommended as part of control practices on the movements of personnel, the sterilization and laundering practices, and the disposal of these garments.

Both reusable and disposable laboratory clothing are available from supply houses. Reusable clothing, although initially more expensive, has the potential of longer life. It should be of a quality capable of withstanding various and repeated decontamination and laundry treatments. Disposable clothing does not have this attribute; however, it has its place in those situations where visitors to the laboratory must be issued clothing, and also in those situations where decontamination facilities, such as autoclaves or ethylene oxide sterilizers, are too distant or not readily available. When there is the potential for contamination of the laboratory clothing with hazardous chemicals, the use of disposable articles allows for degradation by incineration.

Reusable laboratory clothing is made principally of cotton and polyester and combinations thereof. Nylon also is used, but is not recommended for clothing that must be autoclaved. Some of the factors that must be considered in the selection of appropriate laboratory garments are comfort, impenetrability, stitching, appearance, type and effectiveness of closures, shrinkage (not to exceed 1%), antistatic properties, style, color, and ability to withstand repeated autoclaving at 250°F. A fabric composed of 65% polyester, 34% cotton and 1% stainless steel metal fibers

(antistatic) has been widely used. Consideration also must be given to the weight of the material used. Heavier fabrics may be required for rough service or work done in cooler atmospheres, as in the case of animal handlers.



FULLY BUTTONED  
LABORATORY COAT

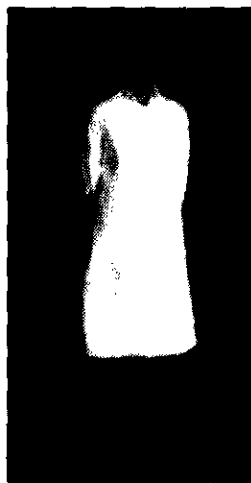

WRAPAROUND SMOCK



SOLID FRONT GOWN



ONE-PIECE  
LABORATORY SUIT

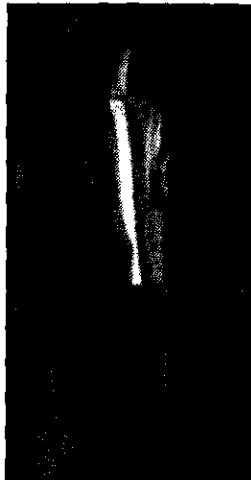

TWO-PIECE  
LABORATORY SUIT

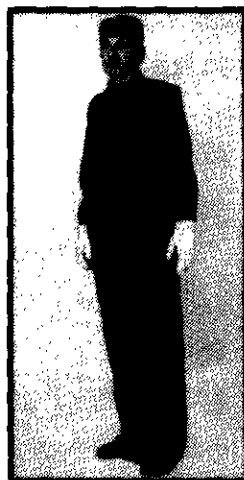

HEAVY DUTY COVERALL

#### TYPES OF LABORATORY CLOTHING

Disposable laboratory clothing, normally, can be obtained from the same companies that supply the reusable garments. Although manufacturers claim that rapidly rising labor costs for decontaminating and laundering make purchase of disposable clothing attractive in contrast to the reusable type, it is up to the individual organization utilizing the clothing to determine which is economical for the intended use. In actual practice, some laboratories report that durable-quality reusable clothing is less expensive.

Two of the popular materials used in the manufacture of disposable garments are made, in one case, from a synthetic polyethylene fiber and, in the second, from cellulose fibers. The synthetic fiber is woven and the cross-fibers are then bonded by heat under pressure. The material so formed has high strength (wet or dry) and presents a good barrier (wet or dry) to movement of particles through it while retaining reasonable breathability for comfort. Its strength permits several days' use of garments under conditions of reasonable activity and wear. The cellulose materials are formed by layering the fibers and bonding the layer to a scrim of nylon mesh. Normally absorbent, the material can be obtained in treated, fluid repellent form. The porosity of this material assures that it breathes. For any of these fabrics, inquiry should be made of the supplier or manufacturer as to their resistance to solvents and solutions of various salts at different pH's in relation to their intended use. Polyethylene generally provides resistance to a broad spectrum of solvents, cellulose fibers less so dependent, in part, upon the surface treatment they are given. Consideration should be given to special needs for self-extinguishing fabrics.

All reusable clothing worn in P1 and P2 facilities can be discarded into a closed container and laundered in the conventional manner if it is not overtly contaminated. Reusable clothing that is from a P3 or P4 facility should be placed in a closed container and subsequently sterilized before laundering. Any clothing, including that from a P1 facility, that may have been overtly contaminated should be wetted down with a disinfectant and autoclaved immediately.

All disposable clothing worn in a P1 facility should be discarded

into a closed container with the other noncontaminated laboratory waste materials and discarded. Disposable clothing that has been used in a P2, P3, or P4 facility should be placed in a closed container and subsequently autoclaved prior to discarding. Again, if it has been overtly contaminated, it should be wetted down with a disinfectant and autoclaved immediately.

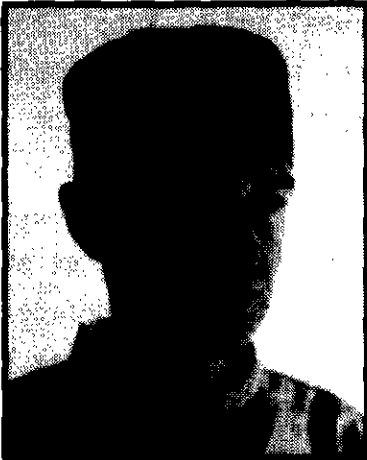

SIMPLE CAP



BOUFFANT CAP



HOODED CAP

TYPES OF HEADCOVERING

## 2. Gloves, Shoes and Aprons

Gloves, shoes and aprons are important items of safety equipment. Gloves must be comfortable and of sufficient length to prevent exposure of the wrists and forearms. Depending on the intended use, the composition and design of a glove may be required to provide dexterity, strength, low permeability, resistance to penetration by sharp objects, and protection against heat and cold. Quality assurance is an important aspect in glove manufacture, and numerous laboratories have experienced difficulty in obtaining leak-proof rubber gloves. Protective footwear is required where there exists the possibility of injury to the feet. Shoes with protective guards or steel toes and capable of resisting penetration of corrosive or hot liquids are available from several safety supply houses. A change to work shoes is beneficial in laboratories handling microbiological materials. This serves to reduce the amount and type of contamination introduced by street shoes and minimizes the possibility of bringing to the home microbiological contamination from the laboratory. Aprons are worn in conjunction with a laboratory coat or suit to minimize penetration of liquid spill or solid particles through the garment to the body surface. They are particularly useful in laboratories handling chemicals. They also are needed in animal handling facilities where washdowns are routinely carried out and in laboratory dishwashing operations where materials are handled in the presence of steam and hot water. Best protection is provided by a solvent resistant, long apron.

### a. Gloves

No one glove can be expected to be satisfactory for all applications. Gloves may be fabricated of cloth, leather, natural (latex) and synthetic (neoprene) rubbers, and plastics. New formulations of synthetic rubbers and plastics continue to be developed as research makes varied and changing demands on the protective capabilities of gloves. Changing applications lead to improved capabilities of low permeability, greater strength, flexibility, tactile sense and control. Even within the

modest laboratory, the requirements to wear gloves may be such that no less than four or five kinds of protective gloves need to be stocked and used.

The type of glove selected is dependent upon the specific activity. For example, delicate work requires the use of thin-walled gloves. Heat-resistant gloves and mittens are an absolute necessity in biomedical laboratories for such operations as handling hot glassware or dry ice. Leather-gauntlet gloves are frequently used when handling certain animals, such as monkeys. For some glove styles, the leather is metal-reinforced to increase protection against animal bites. Other gauntlet-type gloves are needed to protect hands and arms in washroom operations and in working with hazardous chemicals.

Gloves should be worn when working with materials requiring P3 and P4 containment and with toxic substances, and as protection against harmful solvents, acids and caustics. If a glove is to provide protection, it must be of a composition that limits penetration and possesses sufficient strength to maintain the integrity of the barrier under stresses to which the glove is subjected. The data in the table provide some indication of the overall performance characteristics of different glove materials. To achieve tactile sense and control, and sometimes for economic reasons, strength may be compromised by reducing the wall thickness (weight) of gloves. Disposable gloves of rubber and plastic may have wall thicknesses on the order of 1.25 to 6.0 mils. Surgical-type gloves principally range from 8 to 10 mils. For work in Class III cabinets, arm-length gloves of neoprene in thicknesses of 15 to 30 mils have been found to be satisfactory. Heavy-duty industrial gloves are 16 to 40 mils thick. Tearing is frequently experienced with the lighter-weight gloves. Some disposable gloves present problems of fit. Surgical gloves of about 9 mils thickness, sized and shaped for the hand, are normally used when tactile sensitivity is required. Canvas, leather, or heat-resistant gloves should be worn over rubber gloves when handling animal cages or other sharp-edged or hot equipment to prevent tears in the gloves and to protect the skin.

The wearing and final disposal of gloves call for thought and care. Operations in open-front safety cabinets should be preplanned

# CHEMICAL RESISTANCE CHART

CHEMICAL	RUBBER	NEOPRENE	BUNA N	POLY VINYL CHLORIDE	POLY VINYL ALCOHOL
<b>ACIDS MINERAL</b>					
Chromic.....	P	F	F	G	NR
Hydrochloric 30%.....	G	E	E	G	NR
Hydrochloric 10%.....	G	E	E	G	NR
Muriatic.....	G	E	E	G	NR
Nitric 70%.....	F	G	P	F	NR
Nitric 10%.....	F	G	P	F	NR
White Fuming Nitric.....	P	P	P	P	NR
Sulfuric 95%.....	G	G	G	F	NR
Sulfuric 10%.....	G	E	G	F	NR
Sulfuric 48%.....	G	E	G	F	NR
Perchloric.....	F	E	E	P	NR
Phosphoric.....	G	E	E	P	NR
<b>ACIDS ORGANIC</b>					
Formic.....	E	E	G	G	NR
Hydrofluoric.....	E	E	E	E	NR
Lactic.....	E	E	E	E	NR
Malic.....	E	E	E	E	NR
Oxalic.....	E	E	E	E	NR
Palmitic.....	E	E	E	E	NR
Phenol.....	E	E	E	E	NR
Silicic.....	E	E	E	E	NR
Tannic.....	E	E	E	E	NR
<b>ALCOHOLS</b>					
Butanol.....	E	E	E	E	NR
Ethyl.....	E	E	E	E	NR
Ethanol.....	E	E	E	E	NR
Isobutyl.....	E	E	E	E	NR
Isopropyl.....	E	E	E	E	NR
Isopropyl.....	E	E	E	E	NR
Methanol.....	E	E	E	E	NR
Wood.....	E	E	E	E	NR
Oxyl.....	E	E	E	E	NR
<b>ALDEHYDES</b>					
Acetaldehyde.....	G	E	G	G	NR
Benzaldehyde.....	E	E	E	E	NR
Formaldehyde.....	E	E	E	E	NR
<b>CAUSTICS</b>					
Ammonium Hydroxide.....	E	E	E	E	NR
Potassium Hydroxide 50%.....	E	E	E	E	NR
Sodium Hydroxide 50%.....	E	E	E	E	NR
<b>AMINES</b>					
Aniline.....	F	G	G	F	NR
Diethylamine.....	G	G	G	F	NR
Hydrazine.....	G	G	G	F	NR
Methylamine.....	G	G	G	F	NR
Morpholine.....	E	E	E	F	NR
<b>SOLVENTS, AROMATIC</b>					
Benzene.....	NR	P	G	G	NR
Coal Tar Distillate.....	NR	P	G	G	NR
Standard Solvent.....	P	G	G	F	NR
Toluene.....	NR	F	G	F	NR
Toluol.....	NR	F	G	F	NR
Xylol.....	NR	P	G	F	NR
<b>SOLVENTS, KETONIC</b>					
Acetone.....	E	G	P	P	F
Diisobutyl Ketone.....	F	P	F	F	G
Methyl Ethyl Ketone.....	E	G	F	F	G
Methyl Isobutyl Ketone.....	E	G	F	F	G

### COATED GLOVES PHYSICAL PERFORMANCE CHART

PHYSICAL PERFORMANCE	HYDRON	NEOX	REDMONT	SCORPIO	GRABIT	SNORKEL	GRAPPLER	GRIP	MORKEY	PVA
Abrasion Resistance	E	F	G	F	F	F	S	S	F	F
Cut Resistance	E	G	S	G	E	F	F	F	F	F
Dry Grip	E	G	G	E	E	E	G	E	G	G
Flexibility	E	G	G	F	S	F	E	F	G	F
Puncture Resistance	E	E	E	E	E	E	G	G	F	F
Wet Grip	F	F	F	S	G	E	E	F	F	F

KEY TO CHART: S—Superior E—Excellent G—Good F—Fair P—Poor

Courtesy of: Edmont Wilson

### KEY TO CHEMICAL CHART:

S—Fluid has no effect E—fluid has very little effect F—fluid has minor to moderate effect G—fluid has moderate to severe effect NR—no noticeable effect

NOTE: To identify the best glove for each chemical, select the glove with the highest rating for that chemical under the conditions are involved. Then select the glove with the highest ratings for those conditions.

### UNSUPPORTED GLOVES PHYSICAL PERFORMANCE CHART

PHYSICAL CHARACTERISTICS	NEOX	REDMONT	GRABIT	SNORKEL	GRAPPLER	GRIP	MORKEY	PVA
Tensile Strength	E	G	F	F	F	S	S	F
Elongation	E	G	F	F	F	S	S	F
Heat Resistance	E	G	F	F	F	S	S	F
Abrasion Resistance	E	G	F	F	F	S	S	F
Heat Resistance	E	G	F	F	F	S	S	F
Ozone Resistance	E	G	F	F	F	S	S	F

KEY TO CHART: S—Superior E—Excellent G—Good F—Fair P—Poor

so that, once gowned, gloved, seated and with hands and arms in the cabinet, the operator does not have to withdraw from the cabinet until the work has been completed.

Gloves should overwrap the cuff and lower sleeve of the laboratory garment. For further protection of the sleeve, a long glove or a simple disposable plastic arm shield can be used. Armshields can be cut from a roll of polyvinyl chloride or polyethylene; they can be secured at the wrist by the glove. If gloves become overtly contaminated when working in a cabinet, they should be removed and discarded in a waste container in the cabinet with disinfectant sufficient to cover the gloves. New gloves should be available so that work can continue. If the work period is long, it is wise to wipe the gloved hands with disinfectant from time to time.

Arm-length gloves secured to fixed port openings are a requirement in Class III safety cabinets and dry boxes. For this, gloves made of neoprene in thicknesses of 15 to 30 mils have been found to be satisfactory. However, they must be inspected for pinhole leaks as received from the manufacturer and at routine intervals of use. Some manufacturers will give assurance that their gloves have been tested by resistance to high voltage for evidence that they are free of thin areas and pinholes. After intervals of service, and after sterilization of the cabinet system, the gloves, while still attached to the cabinets, should be examined for leaks using the soap bubble test following the certification procedures for Class III Cabinet Systems (III, B, 5).

Decontamination practices for gloves depend upon circumstances. Many activities require that gloves be sterile before use. Surgical procedures on experimental animals require the use of sterile gloves. Many laboratories involved in this kind of program will routinely sterilize all gloves before use. Ethylene oxide or formaldehyde gas sterilization can be used for this purpose. Following treatment, the gloves should be thoroughly aerated in flowing filtered air at 21°C or higher for a minimum of 24 hours to prevent skin burns and irritation from residual disinfectants.



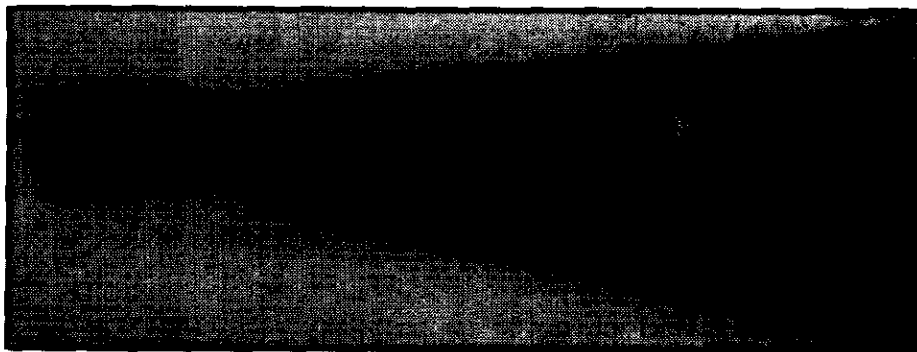

SAFETY CABINET

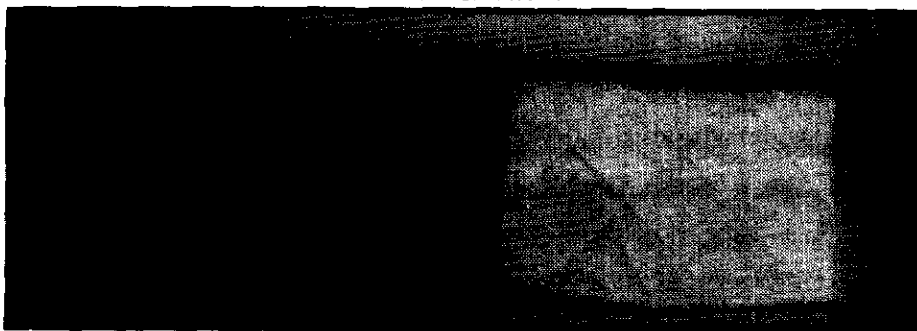

ANIMAL HANDLER (WITH METAL REINFORCEMENTS)

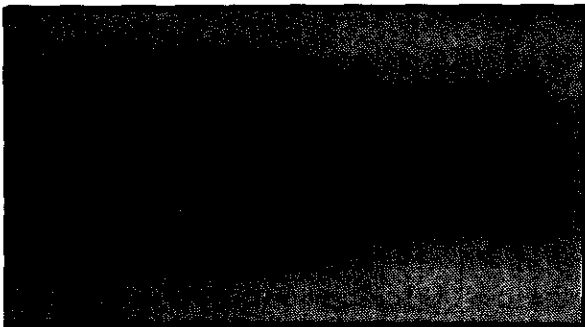

SURGEON'S\*

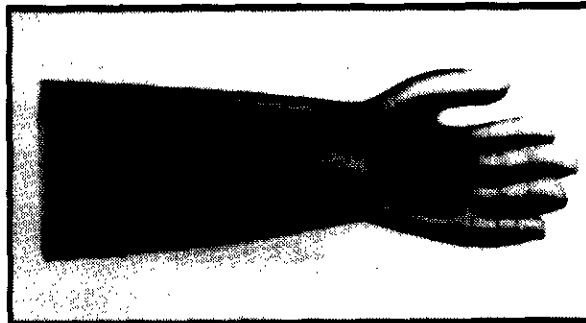

GAUNTLET\*

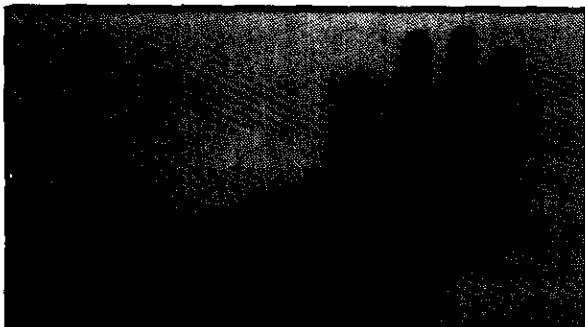

DISPOSABLE\*

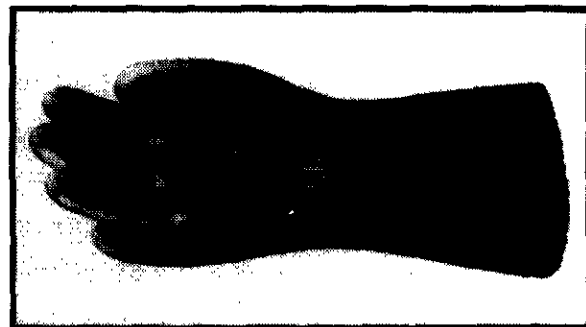

GRIP\*

GLOVES

\*Courtesy of Edmont Wilson

The same procedure can be used for gloves of heavy canvas, leather, or coated material, and for heat-resistant gloves. Heavy-weight, reusable rubber and plastic gloves should be placed in a disinfectant solution following use. After thorough contact of proper duration, they can be washed, rinsed, dried, and stored for reuse. The light-weight disposable gloves and the medium-weight (9 mil) surgical gloves, after use, should be discarded into a covered contaminated waste container for eventual autoclaving.

b. Shoes

Laboratory-issued, steel-toed safety shoes or protective boots should be worn by animal handlers and any workers handling heavy items or corrosive chemicals, whether this occurs in an infectious disease research area or in any other laboratory area. Cage racks, cages, dishwashing trays, and gas cylinders are examples of heavy items commonly handled in laboratory activities that require foot protection. Painful accidents and lost-time absences can result from foot injuries. The complete clothing change required for P4 facilities includes a change to laboratory-issued shoes. "Clean room" activities may require special-issue shoes to protect the experiment and sensitive equipment.

All safety or special-issue shoes and boots used in controlled access areas should be identified so that they can be segregated from other special-issue safety shoes used for work in other areas. Special markings, such as painted toes, can be used to identify shoes worn in biohazard areas. If this is done in a light background color, then numbers or initials can be painted on the background color to identify the wearers. It will be necessary to keep on hand extra shoes in some range of sizes for use by the maintenance staff and visitors.

In the event of overt contamination, the shoes should be sterilized promptly by ethylene oxide or formaldehyde gas. Precautionary decontamination by ethylene oxide or formaldehyde gas should be done on a regularly scheduled routine. Exposing shoes on an ultraviolet (UV) rack or wiping them with a suitable liquid disinfectant such as 8% formalin,

2% iodophor, or 2% phenolic compounds may also be used for decontamination of footwear. However, where there is a known or suspect release of biological material, ethylene oxide or formaldehyde gas treatment is recommended as the most dependable means of decontamination. Whenever a liquid or gaseous disinfectant is used, it is necessary to remove all traces of it following application, to avoid allergic skin reactions to possible burns.

c. Aprons

The penetration of hazardous liquids or particulates to, or through, laboratory clothing can be minimized by the utilization of a solvent resistant, long apron. Plastic or rubber aprons worn over the laboratory garment will provide additional protection. Aprons also are required where equipment is handled in the presence of steam and hot water. Full-length aprons and trousers with cuffs worn outside of shoes and boot tops are recommended.

### 3. Face and Eye Protection

Protection of the face and eyes is of prime importance in laboratories. The possibility is frequently present of impact of foreign material, both liquid and solid, on the head, face, and eyes or on contact lenses. A vast array of face shields, head hoods, protective goggles, and lenses is available from safety supply houses. The selection is dependent upon materials of construction, fit, comfort, compatibility with the disinfectant used, and overall facial area of protection required.

#### a. Face Protection

Face protection against impact and splash can be obtained through the use of face shields and hoods. They serve to protect the face and neck from flying particles and sprays of hazardous materials; however, they do not provide basic eye protection against impacting objects. Shields should be of such design that they cover the entire face, permit tipping back to clear the face, if desired, and are easily removable in the event of an accident. Hoods are hot to wear unless they are obtained with air lines to supply a cooling flow of air.

#### b. Eye Protection

Protection to the eyes is an extremely important matter. Microbiologists and virologists may use chemicals that can cause blindness if splattered into the eye. For example, concentrated quaternary disinfectants splashed in the eye in the course of preparing use-dilutions can cause blindness. Personnel must be cautioned as to this danger and given instruction in use of personal protection for eyes, face and hands. In addition, infection can occur through the conjunctiva of the eyes if a pathogenic microorganism is splattered into the eye.

The supervisor has the responsibility of determining that an eye hazard exists, placarding the area as an "Eye-Hazard Area," determining the type of protection required, and ensuring that the appropriate eye protection equipment is available and worn by the employees. For further



FACE SHIELD



ACID HOOD\*

FACE PROTECTION

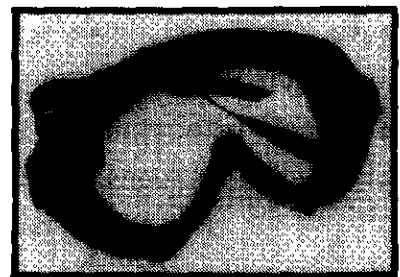
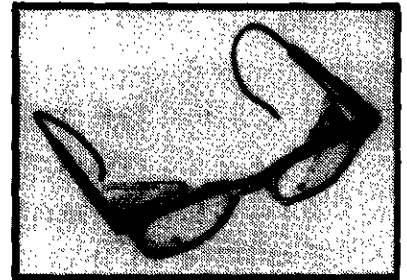
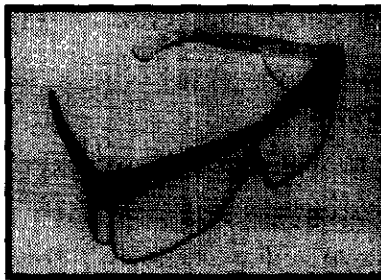
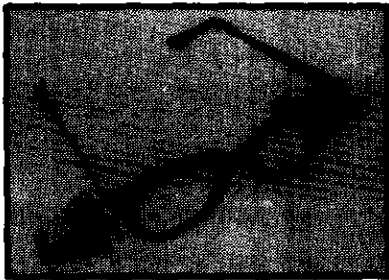

GOGGLES AND SPECTACLES

EYE PROTECTION

\*Courtesy of Mine Safety Appliances Co.

information, consult American National Standards Institute Publication Z87.1-1968, Practice for Occupational and Educational Eye and Face Protection.

Utilization of a few simple common laboratory practices may avoid accidents that result in blindness. Supplies of caustic chemicals should be stored in the smallest size container compatible with daily need at the workbench. In the event of breakage or spill, this will minimize the hazard. Laboratory personnel handling chemicals that may be explosive, corrosive or caustic, or handling cryogenic materials, should be required to wear eye protection.

Personnel who normally wear corrective lenses and work in an area requiring eye protection must wear goggles or spectacles depending on the job assignment. The protective lenses of spectacles should provide optical correction. Goggles should fit over corrective spectacles without disturbing the adjustment of the spectacles or causing leakage, or incorporate corrective lenses mounted behind the protective goggles.

A basic rule to follow is that if an eye hazard exists for a particular operation or experiment, the soundest safety policy would be to require that eye or face protection, or both, be worn at all times by all persons entering or working in the laboratory. Safety glasses with metal or plastic frame spectacles, impact-resistant lenses, and side shields generally are adequate in most situations. Prescription safety lenses fabricated from ground and polished clear glass, or from plastics that may provide longer service life, are frequently required for laboratory personnel. The glass lenses are specially fabricated and heat treated so that they are resistant to impact. However, in those laboratories in which chemicals are used that may cause injury to the eye, it is necessary to use goggles, face shield, or perhaps a combination of them.

If eye protection is deemed necessary in a laboratory, then an emergency eyewash station should be available.

Contact lenses do not provide protection to the eyes. Foreign material present on the surface of the eye may become trapped in the

capillary space between the contact lenses and the cornea. Inert, but sharp, particles, caustic chemicals, irritating vapors, and infectious agents in this space cannot be washed off the surface of the cornea. If the material that gets into the eye is painful, it becomes extremely difficult to remove the contact lens because of the muscle spasms that may develop. In accordance with the position adopted by the National Society for the Prevention of Blindness, it is recommended that contact lenses not be worn around chemicals, fumes, and other hazardous materials and dust particles. The only exception is if a visual problem exists that is corrected only by contact lenses as certified by the employee's physician or optometrist. Where contact lenses are worn, eye protection, such as tight-fitting goggles, must be worn. The eye protective device used with the contact lenses must meet or exceed all the requirements of the American National Standards Institute as specified in Practice for Occupational and Educational Eye and Face Protection, Z87.1-1968.

#### 4. Respiratory Protective Equipment

In recombinant DNA research, respiratory protection is required for emergency procedures and for work in a P4 facility suit area.

There are many kinds of respiratory protective devices from which to choose. They vary in design, application, and protective capability. They can be placed into three categories: air purifying, supplied air, and self-contained breathing apparatus.

##### a. Air-Purifying Respiratory Devices

These may contain both a mechanical filter and a chemical cartridge. The mechanical filter provides protection against biological aerosols. Mechanical filters consist of fibrous material that will remove the particles from air as it passes through the medium; however, they do not protect against harmful gases and vapors.

The chemical cartridge protects against specific gases and vapors present in the atmosphere not in excess of 0.1% by volume. Several types of cartridges are available from safety supply organizations. The type to be used for a particular operation is dependent upon the chemical protection required.

If the air-purifying devices are manufactured as "half-face masks," they protect only against entry through the nose and mouth. A "full-face protective mask" is a more sophisticated air-purifying device, that provides protection to the major portion of the face, eyes, and respiratory tract. It is more efficient in filtering out biological contaminants and removing gases and vapors.

Hospital or contagion-type masks are less efficient forms of air-purifying devices. Today, most of these masks are of the disposable type. Unfortunately, they do not permit a very good face seal. In addition, some exhibit low filtration efficiency.

The effectiveness of all air-purifying devices is dependent upon such factors as the resistance they present to breathing, their comfort when worn for long periods, and the effectiveness of the filter



material in removing particulates of a given size, the peripheral seal of the device, their design, and durability. This category of mask requires an efficient filtering medium and is dependent upon a good peripheral seal because without it the inhaled air will bypass the filter element and provide poor or no protection. A clean-shaven face is required if a mask or respirator is to provide a good face seal.

b. Supplied-Air Respiratory Devices

(1) Air Line Respirators

This device supplies air from a remote filtered source by pipe and hose line to a half- or full-face mask respirator. Air line respirators have been found most useful where maximum respiratory protection is required and where leakage through a filter or peripheral seal cannot be tolerated. The system does have the limitation that if the air supply fails the person using the respirator must leave the area immediately because the central system has a limited reserve air supply tank normally established at a 30-minute reserve. Another disadvantage is that the air supply hose limits the user to a certain fixed range from the air supply.

There are three broad categories of air line respirators: constant flow, demand flow, and pressure demand. Constant flow respirators are generally used under conditions of an ample air supply as supplied by compressors. Demand-type respirators are normally used where compressed air cylinders are available; however, for a laboratory engaged in hazardous activities, this type system is not suitable because of inward leakage caused by negative pressure during inhalation. The pressure-demand air line respirator provides a positive pressure during both inhalation and exhalation, and does not use as much air as the constant flow units.

(2) Air-Supplied Hoods

Air-supplied hoods, or complete suits, that obtain their source of air from an external filtered compressed air source have been used for those operations where it is impractical, or impossible, to isolate the product or hazardous operation in a protective cabinet or

other type enclosure. The air-supplied hoods would be used for those situations in which only a respiratory hazard is involved.

### (3) Self-contained Apparatus

This apparatus operates independently of the surrounding atmosphere, since the mask comes with its own air supply. There are three basic types of self-contained breathing apparatus: oxygen cylinder re-breathing, demand, and self-generating. Normally, they may be used for only very short time periods, 15 to 30 minutes, because of the limited air supply available; however, the system is applicable when leakage through the filter or peripheral seal cannot be tolerated.

Self-contained systems are not used to any great extent in laboratories, except in case of emergencies. For those installations desiring to have a self-contained apparatus on hand in the event of an emergency, contact several of the reputable safety supply concerns and discuss with their technical personnel the various features of these devices before making a final selection.

#### c. Selecting a Respiratory Protective Device

The selection of what respiratory protective device to use should be made with knowledge of the conditions of the research activities and the risk situation involved. Selection should be made jointly by the principal investigator and safety officer. It should be emphasized that the degree of protection required must be thoroughly investigated; and, once determined, the respiratory equipment selected must be inspected and properly fitted. The reputable safety supply houses can provide data as to mask performance based on tests they have conducted or that they know have been performed by research institutions or government agencies referred to previously.

It cannot be overemphasized that there must be a good peripheral seal between the face and the mask. Such conditions as beard growth, temple pieces of eyeglasses, and the absence of one or both dentures all contribute to mask leakage. Full-face masks with prescription lenses

that do not interfere with the mask are available commercially, if required. When assigning a respirator to an individual, especially the half-face respirator, one size or type will not fit all subjects, and it is necessary to have two or more types and sizes of half-face masks available for fitting and use purposes. Determination that the proper tension exists on the respirator headband is also important, because it has been shown that a direct relationship exists between strap tightness and seal. Once the proper mask has been assigned to an individual, the next step is to ascertain that the wearer properly dons and adjusts the mask. Too frequently, adequate peripheral seal is not obtained because a mask is worn improperly.

#### d. Mask Decontamination

The newer type contagion or hospital-type masks are of the disposable category. If masks of this type have been worn in a contaminated area, autoclaving is recommended prior to discard. Where personnel have been working in an area that has resulted in overt contamination of the reusable respiratory protective equipment, ethylene oxide (ETO) must be used to assure complete penetration of the decontaminant. The facepiece, however, must be aerated 24 hours following decontamination because, if there is insufficient aeration, chemical burns can be inflicted on the user. This decontamination process will have an adverse effect on any charcoal filter element, and, therefore, any cartridge or canister that contains this adsorbent as a component of the overall mask should be replaced following sterilization. Autoclaving should not be used, as it has a deleterious effect on some of the compounds used to seal the filter material to the edge of the canister or cartridge.

Personnel using respiratory protection devices should wipe down their equipment with a chemical disinfectant at the end of the day's activity. Several disinfectants may be used. A damp cloth that has been soaked in the disinfectant and the excess squeezed out should be used for the wipe down process of the facepiece. A hypochlorite solution (500 ppm)

with a wetting agent, or alcohol 85%, would be satisfactory. In any wipe down process, it is extremely important to reach all crevices. Following the wipe down procedure, the protective equipment should be thoroughly rinsed with clean, warm water and then exposed to free-flowing air at least 30 minutes before reuse. Valves, head straps, and other parts should be checked. Replace them with new parts, if defective. Insert new filters, cartridges, or canisters, if required; ascertain that the seal is tight. Place in plastic bag or container for storage.

When applied frequently to equipment, several of the available disinfectants will cause corrosion of metal surfaces and require that parts of a mask be replaced from time to time.

For those situations in which personal hygiene is the only consideration, all rubber or plastic face masks and respirators should be scrubbed with a liquid detergent solution and decontaminated. Suitable disinfectants are the quaternary ammonium compounds (200 ppm in water with less than 500 ppm total hardness). Wipe off the decontaminated respiratory device with warm water to remove any residual quaternary compound remaining so as to avoid any possible dermatitis.

Following this decontamination procedure, half-face masks can be stored in plastic bags until required again. Full-face masks or other types of respirators should be stored in cartons or carrying cases, specifically fabricated for the protective equipment.



FULL MASK FACEPIECE

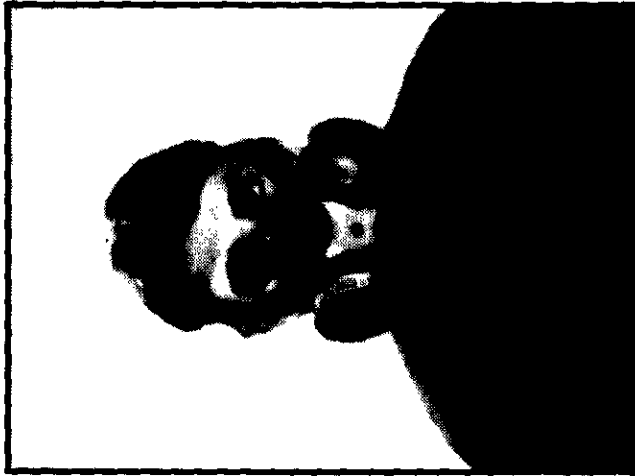

HALF MASK FACEPIECE

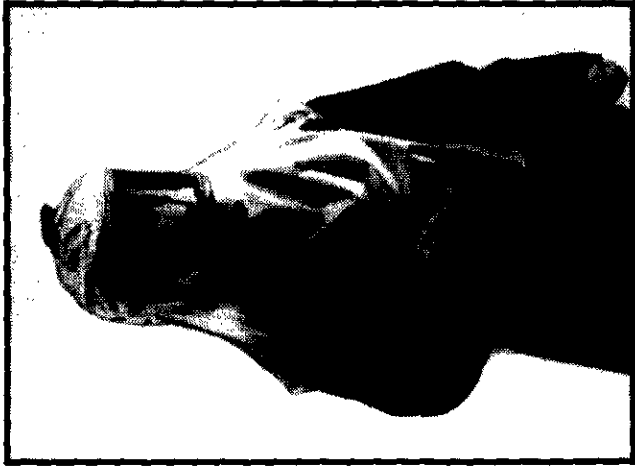

AIR SUPPLIED HEAD HOOD

RESPIRATORY PROTECTIVE EQUIPMENT

Photos Courtesy of Mine Safety Appliances Co.

## 5. Positive Pressure Suits

One-piece positive pressure ventilated suits are required to be worn in all designated suit areas within P4 facilities.

Positive pressure suits are usually fabricated of heavy vinyl material. To provide the wearer with protection in the event the air supply is accidentally disconnected, a biological filter should be installed at the quick disconnect at the suit. This will provide the wearer protection to permit egress from the restricted zone.

Although they have been under development for several years, and many are in use in industry, there still are problems associated with their use. Personnel have found them to be cumbersome, some heat up rapidly in warm weather (especially the complete suits) unless conditioned air and a good air distribution system are provided within the protective garment, and many can be easily torn by sharp edges. Personnel with a good positive attitude adapt well to their use.

It is desirable to provide conditioned air and to include an air distribution system within the suit to permit the user to carry on activities in a comfortable environment. One air conditioning device utilizes a vortex tube that introduces either warm or cooled air. After use in a contaminated area, suits must be decontaminated by a thorough washdown with a liquid disinfectant. A 2% solution of peracetic acid is suitable and effective but requires special handling and equipment because it is quite corrosive and has an irritating odor.

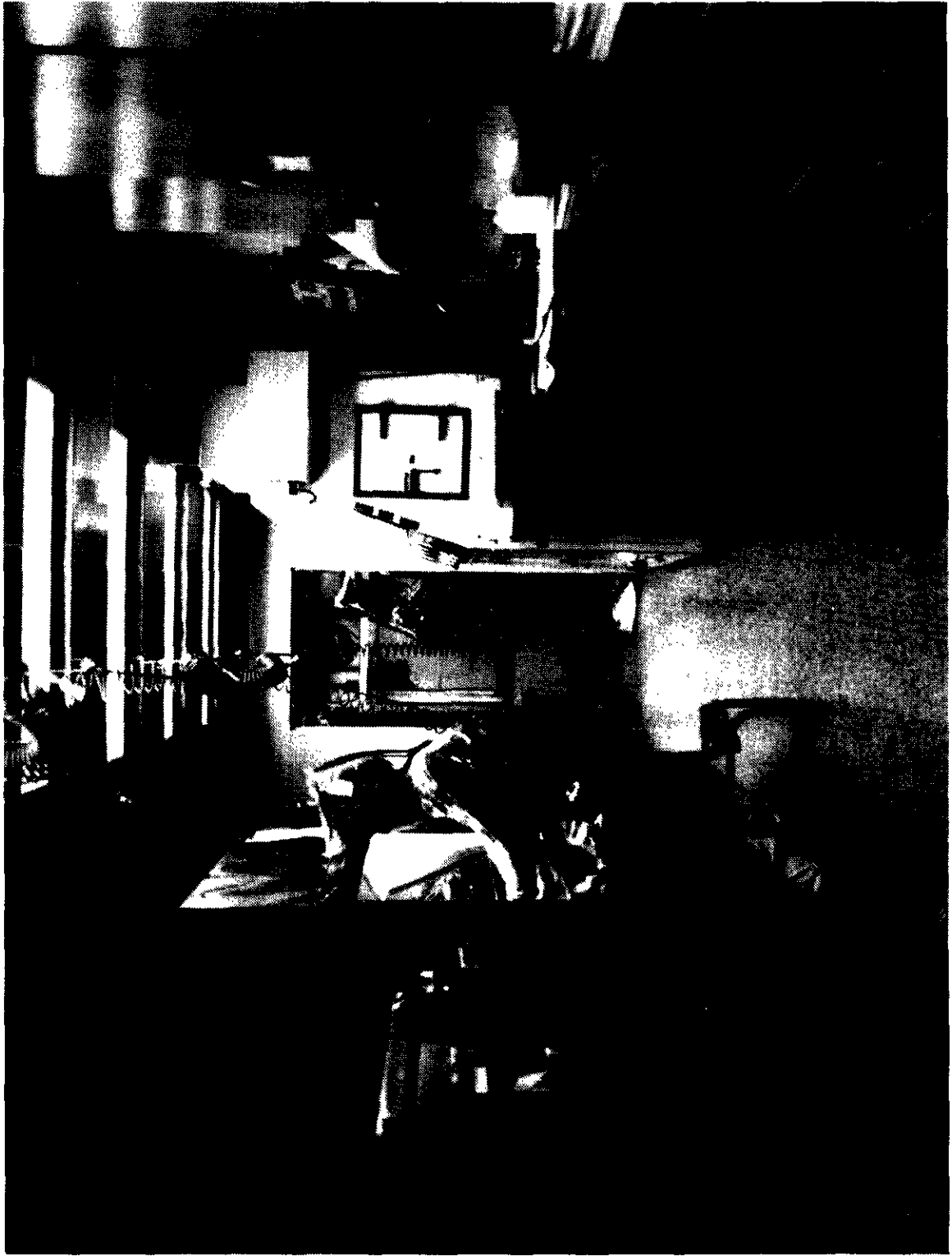

ONE-PIECE POSITIVE PRESSURE VENTILATED SUITS

#### D. Housekeeping

Well-defined housekeeping procedures and schedules are essential in reducing the risks of working with biohazardous materials and in protecting the integrity of the research program. Housekeeping limits physical clutter, controls contamination, and facilitates the efficient use of chemical disinfectants. Although the term "housekeeping" can be broadly interpreted as including procedures such as decontamination, disposal, and animal care, the interpretation given here relates only to the concept of physical cleaning; those tasks universally considered to be janitorial in nature.

The objectives of housekeeping in the biological laboratory are to:

- provide an orderly and clean work area conducive to the accomplishment of the research program,
- provide work areas devoid of physical hazards,
- prevent the accumulation of materials from current and past experiments that constitute a hazard to laboratory personnel, and
- prevent the creation of aerosols of hazardous materials as a result of the housekeeping procedures used.

Procedures developed in the area of housekeeping should be based on the highest level of risk to which the personnel and integrity of the experiments will be subject. Such an approach avoids the confusion of multiple practices and retraining of personnel. The primary function, then, of routine housekeeping procedures is to prevent the accumulation of wastes that (i) may harbor microorganisms that are a potential threat to the integrity of the biological systems under investigation, (ii) may enhance the survival of microorganisms inadvertently released in experimental procedures, (iii) may retard penetration of disinfectants, (iv) may be transferable from one area to another on clothing and shoes, (v) may, with sufficient buildup, become a biohazard as a consequence of secondary aerosolization by personnel and air movement, and (vi) may cause allergic sensitization of personnel, e.g., to animal danders.

Housekeeping in animal care units has the same primary function as that stated for the laboratory and should, in addition, be as meticulously



carried out in quarantine and conditioning areas as in areas used to house experimentally infected animals. No other areas in the laboratory have the constant potential for creation of significant quantities of contaminated wastes than do animal care facilities.

In all laboratories, efforts to achieve total decontamination or to conduct a major cleanup are normally undertaken at relatively long time intervals. Routine housekeeping must be relied on to provide a work area free of significant sources of background contamination. The provision of such a work area is not simply a matter of indicating in a general way what has to be done, who will do it, and how often. The supervisor must view each task critically in terms of the potential biohazard involved, decide on a detailed procedure for its accomplishment, and provide instructions to laboratory personnel in a manner that minimizes the opportunity for misunderstanding.

The following checklist outlines a portion of the items requiring critical review by the laboratory supervisor. It is not intended to be complete, but is presented as an example of the detailed manner in which housekeeping in the biological laboratory complex must be viewed.

- Administration Areas
- Aisles
- Animal Food Storage
- Animal Bedding Storage
- Biological Safety Cabinets
- Bench Tops and Other Work Surfaces
- Ceilings
- Change Rooms
- Cleaning Solution Disposal
- Cages and Cage Racks
- Dry Ice Chests
- Deep Freeze Chests
- Entry and Exit Ways
- Equipment Storage
- Floors
- Glassware
- General Laboratory Equipment Cleanup
- Hallways
- Incubators
- Instruments
- Insect and Rodent Control

- Light Fixtures
- Mechanical Equipment Areas
- Mops
- Pipes - Wall and Ceiling Hung
- Refrigerators
- Showers
- Supply Storage
- UV Lamps
- Vacuum Cleaners
- Waste Accumulations
- Waste Water Disposal
- Others

Housekeeping in the laboratory is one of the avenues that leads to accomplishing the research program safely. It is important that housekeeping tasks be assigned to personnel who are knowledgeable of the research environment. The recommended approach to housekeeping is the assignment of housekeeping tasks to the research teams on an individual basis for their immediate work areas and on a cooperative basis for areas of common usage. Similarly, animal caretaker personnel should be responsible for housekeeping in animal care areas. The laboratory supervisor must determine the frequency with which the individual and cooperative housekeeping chores need be accomplished. He should provide schedules and perform frequent inspection to assure compliance. This approach assures that research work flow patterns will not be interrupted by an alien cleanup crew, delicate laboratory equipment will be handled only by those most knowledgeable of its particular requirements, and the location of concentrated biological preparations and contaminated equipment used in their preparation and application will be known.

## 1. Floor Care

Avoidance of dry sweeping and dusting will reduce the formation of nonspecific environmental aerosols. Wet mopping or vacuum cleaning with a high-efficiency particulate air (HEPA) filter on the exhaust is recommended.

Careful consideration must be given to design and quality in the selection of cleaning equipment and materials and in their use to prevent the substitution of one hazard for another.

In the absence of overt hazardous spills, the cleaning process commonly will consist of an initial vacuuming to remove all gross particulate matter and a follow-up wet mopping with a solution of chemical decontaminant containing a detergent. Depending on the nature of the surfaces to be cleaned and availability of floor drains, removal of residual cleaning solutions can be accomplished by a number of methods. Among these are: pickup with a partially dry mop, pickup with a wet vacuum that has an adequately filtered exhaust, or removal to a convenient floor drain by use of a floor squeegee.

## 2. Dry Sweeping

While it is recommended that dry sweeping be minimized, this may be the only method available or practicable under certain circumstances. In such cases, sweeping compounds used with push brooms and dry-dust mopheads treated to suppress aerosolization of dust should be used.

Sweeping compounds available from the usual janitorial supply firms fall in three categories:

- wax-based compounds used on vinyl floors and waxed floor coverings
- oil-based compounds for concrete floors
- oil-based compounds with abrasives (such as sand) to achieve a dry scouring action where much soil is present

Dry-dust mopheads can be purchased as treated disposable units or as reusable, washable heads that must be treated with appropriate sprays or by other means to improve their dust-capturing property.

### 3. Vacuum Cleaning

In the absence of a HEPA filter on the exhaust, the usual wet and dry industrial-type vacuum cleaner is a potent aerosol generator. The HEPA-filtered exhaust used in conjunction with a well-sealed vacuum unit, however, can negate this factor because of its ability to pass large volumes of exhaust air while retaining particles with a minimum efficiency of 99.97%. Wet and dry units incorporating a HEPA filter on the exhaust are available from a number of manufacturers. The filter in its housing should provide the rated efficiency.

There are no particular requirements with respect to the manner in which the dry vacuuming is accomplished other than to emphasize that the objective is to remove all debris and particulate matter. The manufacturer's directions adequately detail the frequency of bag changes, filter changes, and mechanical adjustments.

Dry material vacuum-collected during these floor-cleaning activities is potentially contaminated, but the nature of the risk is probably greater to the experiment than to the experimenter. It is wise to effect bag and filter changes and to clean out collection tanks in a manner that will avoid or minimize aerosolizing the contents of the vacuum cleaner.

A vacuum machine that collects debris in a disposable bag is preferable to machines that collect the major debris in a tank and on an exposed primary filter. Even though it may serve as a primary filter, the disposable bag must be removed with caution. A bellows effect may pump dust out of the bag if its intake opening is not sealed before moving it to a plastic bag for transfer out of the area. In any event, the outer surface of the disposable bag will probably bear some dust contamination, which also may occur on inner surfaces of the machine.

To avoid contaminating experimental materials, the emptying of vacuum collection tanks and changing of bags and filters are best done away from the immediate laboratory area, for example, in a small area that can be easily cleaned afterwards. The use of heavy rubber gloves is recommended when removing wastes from tanks in case broken glass is present. After

making the filter changes, all external surfaces of the immediate work area and the equipment should be wiped with a cloth moistened in decontaminant. The operator might plan for a change of laboratory clothing afterwards so as to minimize carrying contamination into other areas of the laboratory.

Avoid use of dry vacuum cleaning equipment in work with high risk agents in the open laboratory. Should it be necessary to use it, it is recommended that gaseous sterilization be used to minimize aerosolization of microorganisms before waste is emptied from the vacuum container. Because complete penetration of sterilizing gases into the collected dry dust may be a problem, all wastes should be placed in a plastic bag, which then is tightly closed and incinerated or disposed of in an approved manner.

When dry vacuum cleaning equipment has been used within a gastight safety cabinet system, it can be treated in an attached double-door carboxyclave (an autoclave equipped with an ethylene oxide gas sterilization system) to allow for removal and emptying of the collection tank.

If a wet vacuum is to be used for pickup of the detergent-germicide solution from the floor, the manufacturer's recommendations on filter life should be followed. In addition, the operation of the vacuum should be closely observed for evidence of operating changes indicating restricted airflow or, conversely, increased flow indicating filter failure. Liquids collected in the vacuum cleaner after floor mopping will contain disinfectant material. These liquids may be poured down a convenient floor drain, except in the case of cleanup wastes from an overt spill. The collected liquid should then be autoclaved or treated with chlorine solution before disposal.

Provisions should be made for regular decontamination of the entire vacuum cleaner with formaldehyde gas or vapor, or ethylene oxide. This should be done after use if the vacuum is used in any manner for cleanup of overt spills of infectious material.

#### 4. Selection of a Cleaning Solution

The selection of a detergent-disinfectant combination for routine cleaning of the laboratory complex should be based on the requirements of the area of greatest potential for contamination by the widest spectrum of microorganisms. With rare exception, this will be identified as the animal holding area and the expected microorganisms may well include fungi, viruses, and the vegetative and spore forms of bacteria. A disinfectant solution for such a range of microorganisms would, however, be expensive and excessively corrosive for routine use. Except in those rare instances where it can be assumed that pathogenic spores are being shed by laboratory animals, the risks from the spores are more likely to affect the experiments than the personnel. The spores tend to be associated with organic debris from bedding and food, thus offering potential for removal or at least a large initial reduction in their numbers by vacuum cleaning. A wide range of cleaning solutions that are mildly sporicidal, reasonably residual, and are not destructive to the physical plant is available. Phenol derivatives in combination with a detergent have these characteristics and have been selected for routine use in a number of research facilities. There are numerous detergent-phenolic combinations available on the market. The phenols are one type of a broad spectrum of biocidal substances that include the mercurials, quaternary ammonium compounds, chlorine compounds, iodophors, alcohols, formaldehyde, glutaraldehyde, and combinations of alcohol with either iodine or formaldehyde. These have been discussed in Section II,E.

The laboratory supervisor should make a selection from the types most readily available that meet the general criteria of effectiveness, residual properties, and low corrosiveness.

## 5. Wet Mopping - Two-Bucket Method

Wet mopping of floors in laboratory and animal care areas is, from a safety standpoint, most conveniently and efficiently accomplished using a two-bucket system. The principal feature of such a system is that fresh detergent-decontaminant solution is always applied to the floor from one bucket, while all spent cleaning solution wrung from the mop is collected in the second bucket. Compact dolly-mounted double-bucket units with foot-operated wringers are available from most janitorial supply houses. A freshly laundered mophead of the cotton string type should be used daily. This requires that a mop with removable head be provided as opposed to a fixed-head type. In practice, the mop is saturated with fresh solution, very lightly wrung into the second bucket and applied to the floor using a figure eight motion of the mophead. After every four or five strokes, the mophead is turned over and the process continued until an area of approximately 100 ft<sup>2</sup> has been covered. After allowing a contact time of five minutes, the solution is removed with either a wet vacuum cleaner with HEPA-filtered exhaust or with the wrung-out mop. The mopping is continued in 100 ft<sup>2</sup> increments until the total floor area has been covered. Floor-cleaning procedures are most effectively completed after the majority of the work force has departed and should progress from areas of least potential contamination to those of greatest potential. Before a mophead is sent to a laundry, it should be autoclaved. Spent cleaning fluids are disposed of by flushing down the drain.

If the cleanup follows an overt spill of infectious material, the spent cleaning solution, after removal from the floor, should be autoclaved or treated with chlorine solution. Chlorine (as household bleach) should be added to give 500 ppm and held for a contact time of 15 minutes before dumping in the sanitary sewer.



## 6. Alternative Floor-Cleaning Method for Animal Care Areas and Areas with Monolithic Floors

The absence of permanently placed laboratory benches and fixed equipment, coupled with the mobility of modern cage racks, makes possible alternate floor-cleaning procedures in animal care facilities. As in all considerations of methodologies in biomedical laboratory facilities, it is necessary to assess the compatibility of procedures and facilities from the hazard point of view. The alternative floor-cleaning procedure to be discussed requires that floors are completely sealed or of monolithic construction so that liquid leakage to adjacent areas does not occur and that floor drains or wet vacuum cleaners are available.

Subsequent to the removal of all debris by dry vacuum, move the cage racks to one side of the room. Cover the floor of the remaining cleared portion of the room with detergent-disinfectant solution applied at a rate of approximately one gallon per 144 ft<sup>2</sup> from a one-gallon tank sprayer, using a setting of the nozzle that will cause the solution to flow on and not create a spray. The nozzle is placed close to the floor. Allow a fifteen-minute contact period; then push the cleaning solution to the floor drain with a large floor squeegee or pick it up with a wet vacuum. Allow the floor to air dry; move the cage racks into the cleaned area, and repeat the process for the remaining floor area. Floor drains in these areas should be rim-flush, at least six inches in diameter, and fitted with a screen or porous trap bucket to catch large debris that escapes the initial dry cleaning. Such screens and baskets should be emptied after treatment with a disinfectant. If space utilization does not require frequent floor washdown, pour a half-gallon of detergent-disinfectant solution into the drain each week to keep the trap in the waste line filled against backup of sewer gases.

#### E. Decontamination and Disposal

Historical data on the efficacy of various antimicrobial chemicals indicate that no major surprises will be forthcoming regarding the susceptibility of organisms containing recombinant DNA molecules. In the absence of adequate information, tests to determine the efficacy of candidate disinfectants should be conducted with the specific agent of interest. The goal of disinfection is not only the protection of personnel and the environment from exposure to biological agents, but also the prevention of contamination of experimental materials by the ubiquitous background of microorganisms. This additional factor should be considered in selecting germicidal materials and methods.

## 1. Disinfectant Methods

Physical and chemical means of disinfection fall into four main categories: Heat, Liquid Disinfectants, Vapors and Gases, and Radiation.

### a. Heat

The application of heat, either moist or dry, is recommended as the most effective method of sterilization. Steam at 121°C under pressure in the autoclave is the most convenient method of rapidly achieving sterility. Dry heat at 160° to 170°C for periods of 2 to 4 hours is suitable for destruction of viable agents on impermeable nonorganic material such as glass, but is not reliable in even thin layers of organic or inorganic material that can act as insulation. Incineration kills microorganisms and serves as an efficient means for disposal.

### b. Liquid Disinfectants

In general, the liquid disinfectants find their most practical use in surface treatment and, at sufficient concentration, as sterilants of liquid waste for final disposal in sanitary sewerage systems.

There are many misconceptions concerning the use of liquid disinfectants. This is due largely to a characteristic capacity of such liquids to perform dramatically in the test tube and to fail miserably in a practical situation. Such failures often occur because proper consideration was not given to such factors as temperature, time of contact, pH, concentration, and the presence and state of dispersion, penetrability and reactivity of organic material at the site of application. Small variations in the above factors may make large differences in effectiveness of disinfection. For this reason, even when used under highly favorable conditions, complete reliance should not be placed on liquid disinfectants when the end result must be sterility.

There are many liquid disinfectants available under a wide variety of trade names. In general, these can be categorized as halogens,

acids or alkalies, heavy metal salts, quaternary ammonium compounds, phenolic compounds, aldehydes, ketones, alcohols and amines. Unfortunately, the more active disinfectants often possess undesirable characteristics, such as corrosive properties. None is equally useful or effective under all conditions.

#### c. Vapors and Gases

A variety of vapors and gases possess germicidal properties. The most useful of these are formaldehyde and ethylene oxide. When these can be employed in closed systems and under controlled conditions of temperature and humidity, sterilization can be achieved. Vapor and gas disinfectants are primarily useful in sterilizing: (i) Biological Safety Cabinets and associated effluent air-handling systems and air filters; (ii) bulky or stationary equipment that resist penetration by liquid surface disinfectants; (iii) instruments and optics that might be damaged by other sterilization methods; and (iv) rooms and buildings and associated air-handling systems.

#### d. Radiation

Ionizing radiation will destroy microorganisms. The germicidal action of X-rays has been known for 80 years. Gamma radiation is used for the destruction of microorganisms in some food products and for the sterilization of certain medical products. Ionizing radiation is not a practical tool for laboratory use. However, ultraviolet radiation (UV) is a practical method for inactivating viruses, mycoplasma, bacteria and fungi. This nonionizing radiation is especially useful for the destruction of airborne microorganisms and, to a lesser extent, for the inactivation of microorganisms on exposed surfaces or for the treatment of products of unstable composition that cannot be treated by conventional methods. The usefulness of ultraviolet radiation as a sanitizer is limited by its low penetrating power. Information is not available regarding the effectiveness of UV irradiation for inactivating microorganisms containing recombinant DNA molecules, but it is highly unlikely that increased resistance to UV is

imparted to a cell by the insertion of recombinant DNA. Ultraviolet light is primarily useful in air locks, animal holding areas, ventilated cabinets and in laboratory rooms during periods of nonoccupancy to reduce the levels of viable airborne microorganisms and to maintain good air hygiene.

## 2. Characteristics of Chemical Disinfectants in Common Use in Laboratory Operations

Those persons working with viable microorganisms will find it necessary to disinfect work areas and materials, equipment, and specialized instruments by chemical methods. Chemical disinfection is necessary because the use of pressurized steam, the most reliable method of sterilization, is not normally feasible for disinfecting large spaces, surfaces, and stationary equipment. Moreover, high temperatures and moisture often damage delicate instruments, particularly those having complex optical and electronic components.

Chemical disinfectants are available as powders, crystals, liquid concentrates or compressed gases. Use concentrations must be determined and dilutions made as required. Chemical disinfectants that are gaseous at room temperature may be useful as space disinfectants. Others become gases at reasonably elevated temperatures and can act as either aqueous surface or gaseous space disinfectants.

Inactivation of microorganisms by chemical disinfectants may occur in one or more of the following ways: (i) coagulation and denaturation of protein, (ii) lysis, (iii) inactivation of an essential enzyme by either oxidation, binding, or destruction of enzyme substrate. The relative resistance to the action of chemical disinfectants can be substantially altered by such factors as: concentration of active ingredient, duration of contact, pH, temperature, humidity, and presence of organic matter. Depending upon how these factors are manipulated, the degree of success achieved with chemical disinfectants may range from minimal inactivation of target microorganisms to sterility within the limits of sensitivity of the assay systems employed.

There are dozens of disinfectants available under a wide variety of trade names. In general, these disinfectants can be classified as acids or alkalies, halogens, heavy metal salts, quaternary ammonium compounds, phenolic compounds, aldehydes, ketones, alcohols, and amines. Unfortunately, the more active the disinfectant, the more likely it will possess undesirable characteristics. For example, peracetic acid is a fast-acting, universal

germicide. However, in the concentrated state it is a hazardous compound that can readily decompose with explosive violence. When diluted for use, it has a short half-life, produces strong, pungent, irritating odors, and is extremely corrosive to metals. Nevertheless, it is such an outstanding germicide that it is commonly used in germ-free animal studies despite these undesirable characteristics.

The halogens are a most active group of disinfectants. Chlorine, iodine, bromide, and fluorine will rapidly kill bacterial spores, viruses, rickettsiae, and fungi. Free halogen is the effective agent. These disinfectants are effective over a wide range of temperatures. The halogens have several undesirable features. They combine readily with protein, so that an excess of the halogen must be used if proteins are present. Also, the halogens are somewhat unstable, especially at lower pH levels, so that fresh solutions must be regularly prepared. Finally, the halogens corrode metals. A number of manufacturers of disinfectants have treated the halogens to control some of these undesirable features. For example, sodium hypochlorite reacts with p-toluenesulfonamide to form Chloramine T, and iodine reacts with certain surface-active agents to form the popular iodophors. These "tamed" halogens are relatively stable, nontoxic, odorless, and less corrosive to metals. The buffering of these compounds, however, decreases their germicidal effectiveness. This trade-off is required when these compounds are used in metal pans or dunk tanks.

Ineffectiveness of a disinfectant is often due to the failure of the disinfectant to contact the microorganism rather than failure of the disinfectant to act. If one places an item in a liquid disinfectant, one can see that the item is covered with tiny bubbles. Of course, the area under the bubbles is dry, and microorganisms in these dry areas will not be affected by the disinfectant. Also, if there are spots of grease, rust or dirt on the object, microorganisms under these protective coatings will not be contacted by the disinfectant. Scrubbing an item when immersed in a disinfectant is helpful, and a disinfectant should have, and most do have, incorporated surface-active agents.

### 3. Properties of Some Common Disinfectants

#### a. Alcohol

Ethyl or isopropyl alcohol in a concentration of 70-85% by weight is often used. Alcohols denature proteins and are somewhat slow in their germicidal action. However, they are effective disinfectants against lipid-containing viruses.

#### b. Formaldehyde

Formaldehyde for use as a disinfectant is usually marketed at about 37% concentration of the gas in water solution referred to as formalin or as a solid polymerized compound called paraformaldehyde. Formaldehyde in a concentration of 5% active ingredient is an effective liquid disinfectant. Formaldehyde at 0.2 to 0.4% is often used to inactivate viruses in the preparation of vaccines. Formaldehyde loses considerable disinfectant activity at refrigeration temperatures. Its pungent, irritating odor requires that care be taken when using formaldehyde solutions in the laboratory. Formaldehyde vapor generated from formaldehyde solution is an effective space disinfectant for sterilizing rooms or buildings. Formaldehyde gas can be generated by heating paraformaldehyde to depolymerize it. In the absence of high moisture content in the air, formaldehyde released in the gaseous state forms less polymerized residues on surfaces and less time is required to clear treated areas of fumes than formaldehyde released in the vapor state.

#### c. Phenol

Phenol itself is not often used as a disinfectant. The odor is somewhat unpleasant and a sticky, gummy residue remains on treated surfaces. This is especially true during steam sterilization. Although phenol itself may not be in widespread use, phenol homologs and phenolic compounds are basic to a number of popular disinfectants. The phenolic compounds are effective disinfectants against some viruses, rickettsiae, fungi and vegetative bacteria. The phenolics are not effective in ordinary usage against bacterial spores.



d. Quaternary Ammonium Compounds or Quats

After 40 years of testing and use, there is still considerable controversy about the efficacy of the "Quats" as disinfectants. These cationic detergents are strongly surface-active and this detergency property makes them good surface cleaners. The Quats will attach to protein so that dilute solutions of Quats will lose effectiveness in the presence of proteins. The Quats tend to clump microorganisms and are neutralized by anionic detergents, such as soap. The Quats are bacteriostatic, tuberculostatic, sporostatic, fungistatic and algistatic at low concentrations. They are bactericidal, fungicidal, algicidal and virucidal against lipophilic viruses at medium concentrations, but they are not tuberculocidal, sporicidal or virucidal against hydrophilic viruses even at high concentrations. The Quats have the advantages of being odorless, nonstaining, noncorrosive to metals, stable, inexpensive and relatively nontoxic.

e. Chlorine

This halogen is a universal disinfectant active against all microorganisms, including bacterial spores. Chlorine combines with protein and rapidly decreases in concentration in its presence. Free, available chlorine is an active element. It is a strong oxidizing agent, corrosive to metals. Chlorine solutions will gradually lose strength so that fresh solutions must be prepared frequently. Sodium hypochlorite is usually used as a base for chlorine disinfectants. An excellent disinfectant can be prepared from household or laundry bleach. These bleaches usually contain 5.25 percent available chlorine or 52,500 ppm. If one dilutes them 1 to 100, the solution will contain 525 ppm of available chlorine; and if a nonionic detergent is added in a concentration of about 0.7 percent, a very good disinfectant is created.

f. Iodine

The characteristics of chlorine and iodine are similar. One of the most popular groups of disinfectants used in the laboratory is the

iodophors, and Wescodyne is perhaps the most widely used. The range of dilution of Wescodyne recommended by the manufacturer is 1 oz. in 5 gal. of water giving 25 ppm of available iodine to 3 oz. in 5 gal. giving 75 ppm. At 75 ppm, the concentration of free iodine is .0075 percent. This small amount can be rapidly taken up by extraneous protein present. Clean surfaces or clear water can be effectively treated by 75 ppm available iodine, but difficulties may be experienced if any appreciable amount of protein is present. For washing the hands or for use as a sporicide, it is recommended that Wescodyne be diluted 1 to 10 or 10% in 50% ethyl alcohol, which will give 1,600 ppm of available iodine at which concentration relatively rapid inactivation of any and all microorganisms will occur.

#### 4. Vapors and Gases for Space Decontamination

The use of formaldehyde as a vapor or gas has already been discussed. Other chemical disinfectants that have been used as space decontaminants include ethylene oxide, peracetic acid, beta-propiolactone (BPL), methyl bromide, and glutaraldehyde. When these can be used in closed systems and under controlled conditions of temperature and humidity, excellent disinfection can be obtained. Ethylene oxide adsorbed by materials such as rubber must be removed by aeration; otherwise, ethylene oxide is convenient to use, versatile, and noncorrosive. Peracetic acid is corrosive for metals and rubber. BPL is not recommended as a space disinfectant, since it is listed as a carcinogen by OSHA (Federal Register, Part III, Vol. 39, No. 20, January 29, 1974).

Formaldehyde is, in general, the chemical of choice for space disinfection. Safety cabinets, incubators, refrigerators, laboratory rooms, buildings, or other enclosed spaces can be disinfected with formaldehyde. The formaldehyde can be generated from aqueous solutions (formalin) containing 37-40% formaldehyde by heating or by vaporizing the solution. Formaldehyde gas, also, can be generated by heating paraformaldehyde, which is a solid polymer that contains 91 to 99% formaldehyde. If aqueous formaldehyde is used, the application rate should be one milliliter for each cubic foot of space to be treated. Also, if a small amount of exhaust air is used to keep the area being treated under a slightly reduced pressure, then this amount must be known, and one milliliter of formalin added for each cubic foot of exhaust air for at least a one-hour period. To assure thorough mixing, the use of air-circulating fans may be required. Areas being treated should have a temperature of at least 70°F (21°C) and a relative humidity of above 70%. Spaces being treated should not be wet, have condensate on the walls, or have pools of water on the floor, since formaldehyde is quite soluble in water and will be rapidly taken up. Also, as the water evaporates, polymerization will take place on the surfaces and these polymers are difficult to remove. Formaldehyde is a powerful reducing agent and is noncorrosive to metals. It can normally be assumed that any equipment or apparatus that will not be damaged by the humidity

necessary for decontamination will not be damaged by the formaldehyde. Although formaldehyde will sterilize all exposed surfaces, it has limited penetrating abilities, and materials that are tightly covered may not be sterilized. This lack of penetrating power is often an advantage in using formaldehyde, since the space need only be enclosed relatively tightly, and not hermetically sealed -- a condition impossible to achieve when rooms or buildings are being treated.

Generally, the generation of formaldehyde gas from powdered or flake paraformaldehyde by heating is the preferred method. Paraformaldehyde will depolymerize and convert to the gaseous state when heated to a temperature above 150°C. There are various practical methods for heating the paraformaldehyde to above 150°C., but the commercially available electric frying pan equipped with a thermostat is one of the simplest. The electric cord of the frying pan should be equipped with a one-hour timer so that the pan can be placed in the space to be treated and, after the submission of the formaldehyde gas, the power to the frying pan will be turned off automatically. The frying pan can hold one kilogram of flake formaldehyde. The depolymerization rate of paraformaldehyde is about 20 g per minute when the thermostat is set at 232°C. A concentration of 0.3 g of paraformaldehyde for each cubic foot of space to be treated is employed. Temperature of the space must be above 20°C and relative humidity 70% or higher. Exposure times should be at least two hours and, if possible, the exposure should be for eight hours or overnight. Formaldehyde generated from paraformaldehyde has better penetration, and fewer problems with condensation and subsequent need for prolonged aeration, than with formaldehyde generated from formalin. If walls and surfaces were not wet with condensation during the formaldehyde treatment process, then aeration and removal of the formaldehyde should proceed rapidly. A small room with nonporous surfaces and no materials or equipment in the room can be cleared of all detectable formaldehyde in less than an hour of aeration. However, an entire building containing a variety of surfaces and equipment may take many hours or even a day or more of aeration to remove the formaldehyde.

Formaldehyde is a toxic substance having a threshold limit value (TLV) of 2 ppm. Considerable caution must be exercised in handling, storing and using formaldehyde. Repeated exposure to formaldehyde is known to produce a hypersensitive condition in certain individuals. Self-contained breathing apparatus, air-supplied masks or industrial-type gas masks should be available and used whenever exposure to formaldehyde is possible. Most individuals can readily detect formaldehyde in a concentration of 1 ppm, which serves as a warning to avoid excessive exposure. Chemicals, such as anhydrous ammonia, have been used to neutralize formaldehyde and deposited paraformaldehyde with limited success. Air containing formaldehyde can be passed through alumina to adsorb the formaldehyde. This technique is useful in removing formaldehyde from cabinets and other small places, but impractical quantities of alumina are required for removing the formaldehyde from large rooms or buildings. Recent reports indicate that formaldehyde may combine with hydrochloric acid to form bis(chloromethyl) ether, a compound which is carcinogenic. When formaldehyde is to be used as a space disinfectant, the area to be treated should be surveyed to insure that there are no open containers of any acidic solution containing chloride ion. It should be mentioned that formaldehyde in the concentrations used for space disinfection has no effect on cockroaches nor possibly on other insects or arachnids as well.

Formaldehyde is explosive at concentrations between 7.0 and 73.0% by volume in air. This concentration, however, cannot be reached when standard procedures are used.

## 5. Residual Action of Disinfectants

As noted in the preceding discussion of disinfectant properties, some of the chemical disinfectants have residual properties that may be considered a desirable feature in terms of aiding in the control of background contamination. One is cautioned, however, to consider residual properties carefully. Ethylene oxide used to sterilize rubber products may be adsorbed by the rubber and desorbed slowly. Therefore, if the rubber products (shoes, gloves, respirators) are not thoroughly aerated (e.g., at least 24 hours), the ethylene oxide leaving the rubber material that is in contact with the skin may cause severe skin irritation. Cell cultures, as well as viruses of interest, may be inhibited or inactivated by disinfectants persisting after routine cleaning procedures. Therefore, reusable items that are routinely held in a liquid disinfectant prior to autoclaving and cleaning should receive particular attention in rinse cycles. Similarly, during general area sterilization with gases or vapors, it may be necessary to protect new and used clean items such as glassware, by removing them from the area or by enclosing them in gastight bags or by insuring adequate aeration following sterilization.

## 6. Laboratory Spills

A problem that may occur in the laboratory is an overt biological spill. A spill that occurs in the open laboratory may create a serious problem. Every effort should be taken to avoid such occurrences. A spill poses less of a problem if it occurs in a Biological Safety Cabinet provided splattering to the outside of the cabinet does not occur. Direct application of concentrated liquid disinfectant and a thorough wipe down of the internal surfaces of such cabinetry will usually be effective for decontaminating the work zone, but gaseous sterilants will be required to disinfect the interior sections of the cabinet. Each researcher must realize that in the event of an overt accident, research materials such as tissue cultures, media, and animals within such cabinets may well be lost to the experiment.

### a. Spill in a Biological Safety Cabinet

A spill that is confined to the interior of the Biological Safety Cabinet should present little or no hazard to personnel in the area. However, chemical disinfection procedures should be initiated at once while the cabinet ventilation system continues to operate to prevent escape of contaminants from the cabinet. Spray or wipe walls, work surfaces, and equipment with a disinfectant. A disinfectant with a detergent has the advantage of detergent activity, which will help clean the surfaces by removing both dirt and microorganisms. A suitable disinfectant is a 3% solution of an iodophor such as Wescodyne or a 1 to 100 dilution of a household bleach (e.g. Clorox) with 0.7% nonionic detergent. The operator should wear gloves during this procedure. Use sufficient disinfectant solution to ensure that the drain pans and catch basins below the work surface contain the disinfectant. Lift the front exhaust grill and tray and wipe all surfaces. Wipe the catch basin and drain the disinfectant into a container. This disinfectant, gloves, wiping cloth and sponges should be discarded into an autoclave pan and autoclaved. This procedure will not disinfect the filters, blower, air ducts or other

interior parts of the cabinet. If the entire interior of the cabinet is to be sterilized, then this can be accomplished by the formaldehyde gas method using powdered or flake paraformaldehyde. Calculate the volume of the cabinet in cubic feet and weigh out 0.3 g of flake paraformaldehyde for each cubic foot of space. Place the paraformaldehyde in the frying pan and place the pan in the cabinet with the electric line run to the outside of the cabinet. Raise the humidity within the cabinet to about 70%. Vaporization of water in the frying pan is a convenient technique. Set the thermostat of the frying pan containing the paraformaldehyde at 450° F. Seal the cabinet opening with sheet plastic and tape. If the cabinet exhaust air is discharged into the room, attach flex hose to the cabinet exhaust port and extend the hose to the room exhaust grille; however, if the building exhaust air recirculates, attach flex hose to an open window or door. If the cabinet is exhausted directly into the building system, close the exhaust damper. Plug in the frying pan to depolymerize the paraformaldehyde. After one-half volume of paraformaldehyde has been depolymerized, turn on the cabinet fan for about three seconds to allow the formaldehyde gas to reach all areas. After depolymerization is complete, again turn on the cabinet fan for three seconds. Then allow the cabinet to stand for a minimum of one hour. After the one-hour exposure, open the flex hose on the exhaust damper, slit the plastic covering the opening and turn on the cabinet fan. Ventilate the cabinet for several hours to remove all traces of formaldehyde.

b. Spill in the Open Laboratory

If potentially hazardous biological material is spilled in the laboratory, the first essential is to avoid inhaling any airborne material by holding the breath and leaving the laboratory. Warn others in the area and go directly to a wash or change room area. If clothing is known or suspected to be contaminated, remove the clothing with care, folding the contaminated area inward. Discard the clothing into a bag or place the clothing directly in an autoclave. Wash all potentially contaminated areas



as well as the arms, face and hands. Shower if facilities are available. Reentry into the laboratory should be delayed for a period of 30 minutes to allow reduction of the aerosol generated by the spill. Advance preparation for management of a spill is essential. A "spill kit," including leak-proof containers, forceps, paper towels, sponges, disinfectant, respirators, and rubber gloves, should be readily available. A high-intensity, portable ultraviolet lamp is useful in emergency situations. This UV lamp can be moved into the room where the accident occurred and the automatic timer set for a given period of exposure. A delay timer allows sufficient time to get out of the room before the UV lamp is automatically activated. The door to the room should be locked or a sign posted on the door warning personnel not to enter as 1200 watts of radiation is emitted by this lamp. A 2-3 hour exposure will sterilize microorganisms that either may be airborne or have settled on exposed surfaces. Radiant energy at  $253.7\mu$  has little penetrating power so that microorganisms covered with dirt or dust will probably not be affected.

Protective clothing should be worn when entering the laboratory to clean the spill area. Rubber gloves, autoclavable footwear, an outer garment and a respirator should be worn. If the spill was on the floor, do not use a surgical gown that may trail on the floor when bending down. Take the "spill kit" into the laboratory room, place a discard container near the spill, and transfer large fragments of material into it; replace the cover. Using a hypochlorite containing 1,000 ppm available chlorine, iodophor solution containing 1,600 ppm iodine, or other appropriate disinfectant, carefully pour the disinfectant around and into the visible spill. Avoid splashing. Allow 15 minutes' contact time. Use paper or cloth towels to wipe up the disinfectant and spill, working toward the center of the spill. Discard towels into a discard container as they are used. Wipe the outside of the discard containers, especially the bottom, with a towel soaked in a disinfectant. Place the discard container and other materials in an autoclave and sterilize. Remove shoes, outer clothing, respirator and gloves and sterilize by autoclaving or exposure to ethylene oxide. Wash hands, arms and face or, if available, shower. If gaseous

disinfection of the laboratory room is to be carried out, follow the procedures as outlined in Section II. E. 4.

c. Radioactive Biohazard Spill Outside a Biological Safety Cabinet

In the event that a biohazardous spill also involves a radiation hazard, the cleanup procedure may have to be modified, depending on an evaluation of the risk assessment of relative biological and radiological hazard.

Laboratories handling radioactive substances will have the services of the designated radiation area supervisor to aid in the cleanup. Before cleanup procedures begin, a radiation protection officer should survey the spill for external radiation hazard to determine the degree of risk. In most cases, the spill will involve  $^{14}\text{C}$  or  $^3\text{H}$ , which present no external hazard. However, if more energetic beta or gamma emitters are involved, care must be taken to prevent hand and body radiation exposure. The radiation protection officer must make this determination before the cleanup operation is begun.

If the radiation protection officer approves, the biohazard handling procedure may begin: Using an autoclavable dust pan and squeegee, transfer all contaminated materials (paper towels, glass, liquid, gloves, etc.) into a deep autoclave pan. Cover the pan with aluminum foil or other suitable cover and autoclave according to standard directions.

If the radiation protection officer determines that radioactive vapors may be released and thereby contaminate the autoclave, the material must not be autoclaved. In that case, sufficient disinfectant solution to immerse the contents should be added to the waste container. The cover should be sealed with waterproof tape, and the container stored and handled for disposal as radioactive waste. Radioactive and biohazard warning symbols should be affixed to the waste container. As a general rule, autoclaving should be avoided. A final radioactive survey should be made of the spill area, cleanup tools, and shoes and clothing of individuals who had been in the area by taking swipes and counting in an appropriate counter.

## 7. Disposal

Decontamination and disposal in infectious disease laboratories are closely interrelated acts in which disinfection constitutes the first phase of disposal. All materials and equipment used in research on recombinant DNA molecules will ultimately be disposed of; however, in the sense of daily use, only a portion of these will require actual removal from the laboratory complex or on-site destruction. The remainder will be recycled for use either within the same laboratory or in other laboratories that may or may not engage in recombinant DNA research. Examples of the latter are: reusable laboratory glassware, instruments used in necropsy of infected animals, and laboratory clothing. Disposal should therefore be interpreted in the broadest sense of the word, rather than in the restrictive sense of dealing solely with a destructive process.

The principal questions to be answered prior to disposal of any objects or materials from laboratories dealing with potentially infectious microorganisms or animal tissues are:

- Have the objects or materials been effectively disinfected or sterilized by an approved procedure?
- If not, have the objects or materials been packaged in an approved manner for immediate on-site incineration or transfer to another laboratory?
- Does disposal of the disinfected or sterilized objects or materials involve any additional potential hazards, biological or otherwise, to those carrying out the immediate disposal procedures or those who might come into contact with the objects or materials outside the laboratory complex?

Laboratory materials requiring disposal will normally occur as liquid, solid, and animal room wastes. The volume of these can become a major problem when there is the requirement that all wastes be disinfected prior to disposal. It is most evident that a significant portion of this problem can be eliminated if the kinds of materials initially entering the laboratory are reduced. In any case, and wherever possible, materials not essential to the research should be retained in the nonresearch areas for

disposal by conventional methods. Examples are the packaging materials in which goods are delivered, disposable carton-cages for transport of animals, and large carboys or tanks of fluids that can be left outside and drawn from as required. Reduction of this bulk will free autoclaves and other decontamination and disposal processes within the laboratory for more rapid and efficient handling of materials known to be contaminated.

Inevitably, disposal of materials raises the question, "How can we be sure that the materials have been treated adequately to assure that their disposal does not constitute a hazard?" In the small laboratory, the problem is often solved by having each investigator disinfect all contaminated materials not of immediate use at the end of each day and place them in suitable containers for routine disposal. In larger laboratories, where the mass of materials for disposal becomes much greater and sterilization bottlenecks occur, materials handling and disposal will likely be the chore of personnel not engaged in the actual research. In either situation, a positive method should be established for designating the state of materials to be disposed. This may consist of a tagging system stating that the materials are either sterile or contaminated.

Disposal of materials from the laboratory and animal holding areas will be required for research projects ranging in size from an individual researcher to those involving large numbers of researchers of many disciplines. Procedures and facilities to accomplish this will range from the simplest to the most elaborate. The primary consideration in any of these is to dispel the notion that laboratory wastes can be disposed of in the same manner, and with as little thought, as household wastes. Selection and enforcement of safe procedures for disposal of laboratory materials are of no less importance than the consideration given to any other methodology for the accomplishment of research objectives.

Materials of dissimilar nature will be common in laboratories studying recombinant DNA molecules. Examples are combination of common flammable solvents, chemical carcinogens, radioactive isotopes, and concentrated viruses or nucleic acids. These may require input from a number of disciplines in arriving at the most practical approach for their decontamination and disposal.

## 8. Selecting Chemical Disinfectants in Recombinant DNA Research

No single chemical disinfectant or method will be effective or practical for all situations in which decontamination is required. Selection of chemical disinfectants and procedures must be preceded by practical consideration of the purposes for the decontamination and the interacting factors that will ultimately determine how that purpose is to be achieved. Selection of any given procedure will be influenced by the information derived from answers to the following questions:

- What is the target organism(s) (i.e., host, vector, and donor organism from which DNA segments are obtained)?
- What disinfectants, in what form, are known to, or can be expected to, inactivate the target organism(s)?
- What degree of inactivation is required?
- In what menstruum is the organism suspended (i.e., simple or complex, on solid or porous surfaces, and/or airborne)?
- What is the highest concentration of cells anticipated to be encountered?
- Can the disinfectant, either as a liquid, a vapor, or gas, be expected to contact the organisms, and can effective duration of contact be maintained?
- What restrictions apply with respect to compatibility of materials?
- What is the stability of the disinfectant in use concentrations, and does the anticipated use situation require immediate availability of the disinfectant or will sufficient time be available for preparation of the working concentration shortly before its anticipated use?

The primary target of decontamination in the laboratory is the organism(s) under investigation. Laboratory preparations or cultures usually have titers in excess of those normally observed in nature. Inactivation of these materials presents other problems, since agar, proteinaceous nutrients, and cellular materials can effectively retard or chemically bind the active moieties of chemical disinfectants. Such interferences with the desired action of disinfectants may require higher concentrations and longer contact times than those shown to be effective in the test tube. Similarly, a major portion of the contact time required to achieve a given level of agent inactivation may be expended in

inactivating a relatively small number of the more resistant members of the population. The current state of the art provides little information on which to predict the probable virulence of these more resistant cells. These problems are, however, common to all potentially pathogenic agents and must always be considered in selecting disinfectants and procedures for their use.

Organisms exhibit a range of resistance to chemical disinfectants. In terms of practical decontamination, most vegetative bacteria, fungi, and lipid-containing viruses are relatively susceptible to chemical disinfection. The nonlipid-containing viruses and bacteria with a waxy coating, such as tubercle bacillus, occupy a mid-range of resistance. Spore forms are the most resistant.

A disinfectant selected on the basis of its effectiveness against organisms on any range of the resistance scale will be effective against organisms lower on the scale. Therefore, if disinfectants that effectively control spore forms are selected for routine laboratory decontamination, it can be assumed that any other organisms generated by laboratory operations, even in higher concentrations, would also be inactivated.

An additional area that must be considered, and for which there is little published information available, is the "inactivation" of DNA molecules. Strong oxidizers, strong acids and bases, and either gaseous or aqueous formaldehyde, as well as heat sterilization conditions, should react readily with DNA molecules. Chemical disinfectants that are active against the organism from which the DNA is obtained should also be effective in "inactivating" the DNA of the organism. Chemical disinfectants that effectively control spore forms (hypochlorite containing 500 ppm available chlorine and iodophor solution containing 1600 ppm iodine) should be considered excellent candidates for "inactivating" DNA molecules. The ability of disinfectants to destroy the DNA molecule being studied, however, should be confirmed in the experimenter's laboratory.

Pertinent characteristics and potential applications for several categories of chemical disinfectants most likely to be used in the biological laboratory are summarized in the table below. Practical concentrations and contact times that may differ markedly from the recommendations of manufacturers of proprietary products are suggested. It has been assumed that microorganisms will be afforded a high degree of potential protection by organic menstrooms. It has not been assumed that a sterile state will result from application of the indicated concentrations

#### SUMMARY OF PRACTICAL DISINFECTANTS FOR

DISINFECTANTS		PRACTICAL REQUIREMENTS				INACTIVATES				IMPORTANT CHARACTERISTICS						
		Use Dilution	Contact Time (Minutes)		Temperature, °C	Relative Humidity, %	Vegetative Bacteria	Lipoviruses	Nonlipid Viruses	Bacterial Spores	Effective Shelf Life > 1 week <sup>c</sup>	Corrosive	Flammable	Explosion Potential	Residue	Inactivated by Organic Matter
Lipovirus	Broad Spectrum															
TYPE	CATEGORY															
Liquid	Quat. Ammon. Cpds	0.1 - 2.0%	10	NE			+	+		+					+	+
	Phenolic Cpds	1.0 - 5.0%	10	NE			+	+	b	+				+		
	Chlorine Cpds	500 ppm <sup>a</sup>	10	30			+	+	+	+	+				+	+
	Iodophor	25 - 1600 ppm <sup>a</sup>	10	30			+	+	+	+	+				+	+
	Alcohol, Ethyl	70 - 85%	10	NE			+	+	b		+		+			
	Alcohol, Isopropyl	70 - 85%	10	NE			+	+	b		+		+			
	Formaldehyde	0.2 - 8.0%	10	30			+	+	+	+	+				+	
	Glutaraldehyde	2%	10	30			+	+	+	+				+		+
Gas	Ethylene Oxide	8 - 23 g/ft <sup>3</sup>	60	60	37	30	+	+	+	+	NA		+ <sup>d</sup>	+ <sup>d</sup>		+
	Paraformaldehyde	0.3 g/ft <sup>3</sup>	60	60	>23	>60	+	+	+	+	NA		+ <sup>e</sup>	+ <sup>e</sup>		+

Note: NA - Not applicable  
NE - Not effective

<sup>a</sup> Available halogen

<sup>b</sup> Variable results dependant on virus

<sup>c</sup> Protected from light and air

<sup>d</sup> Neither flammable nor explosive in 90% CO<sub>2</sub> or fluorinate hydrocarbon, the usual use form

<sup>e</sup> At concentrations of 7 to 73% by volume in air, solid-exposure to open flame

and contact times. It should be emphasized that these data are only indicative of efficacy under artificial test conditions. The efficacy of any of the disinfectants should be conclusively determined by individual investigators. It is readily evident that each of the disinfectants has a range of advantages and disadvantages as well as a range of potential for inactivation of a diverse microflora. Equally evident is the need for compromise as an alternative to maintaining a veritable "drug store" of disinfectants.

#### USE IN RECOMBINANT DNA RESEARCH

					POTENTIAL APPLICATION										EXAMPLES OF PROPRIETARY DISINFECTANTS <sup>h</sup>	
Compatible For Electronics	Skin Irritant	Eye Irritant	Respiratory Irritant	Toxic <sup>g</sup>	Work Surfaces	Dirty Glassware	Large Area Decon.	Air Handling Systems	Portable Equip. Surface Decon.	Portable Equip. Penetrating Decon.	Fixed Equip. Surface Decon.	Fixed Equip. Penetrating Decon.	Optical & Electronic Instruments	Liquids For Discard	Books, Papers	
+	+	+		+	+	+			+		+					A-33, CDO, End-Bac, Hi-Tor, Mikro-Quat
	+	+		+	+	+			+		+					Hi-Phene, Matar, Mikro-Bac, O-Syl
	+	+	+	+	+	+			+		+			+		Chloramine T, Clorox, Purex
	+	+		+	+	+			+		+					Hy-Sine, Ioprep, Mikroklene, Wescodyne
		+		+	+	+			+		+					
	+	+		+	+	+			+		+					Sterac
	+	+		+	+	+			+		+					Cidex
+	+	+	+	+						+			+		+	Carboxide, Cryoxidex, Steroxidex
+	+	+	+	+			+	+		+		+	+			

<sup>f</sup> Usually compatible, but consider interferences from residues and effects on associated materials such as mounting adhesives.

<sup>g</sup> By skin or mouth or both - refer to manufacturer's literature and/or Merck Index

<sup>h</sup> Space limitations preclude listing all products available. Individual listings (or omissions) do not imply endorsement or rejection of any product by the National Institutes of Health.



## 9. Caution Required When Applying Disinfectant Methods

### a. Heat Sterilization

The hazards of handling hot solids and liquids are reasonably familiar. Laboratory personnel should be cautioned that steam under pressure can be a source of scalding jets if the equipment for its application is mishandled. Loads of manageable size should be used. Fluids treated by steam under pressure may be superheated if removed from the sterilizer too promptly after treatment. This can cause a sudden and violent boiling of the contents from containers that can splash scalding liquids onto personnel handling the containers.

### b. Liquid Disinfectants

Particular care should be observed when handling concentrated stock solutions of disinfectants. Personnel assigned the task of making up use-concentrations from stock solutions must be properly informed as to the potential hazards and trained in the safe procedures to follow. The concentrated quaternary and phenolic disinfectants are particularly harmful to the eyes. Even a small droplet splashed in the eyes may cause blindness. Protective face shields and goggles should be used for eye protection, and long-sleeved garments and chemically resistant gloves, aprons, and boots should be worn to protect from corrosive and depigmentation effects to the skin. One of the initial sources for hazard information on any given product will be the label on its container.

### c. Vapors and Gases

Avoid inhalation of vapors of formaldehyde and ethylene oxide. Stock containers of these products should be capable of confining these vapors and should be kept in properly ventilated chemical storage areas in the event of inadvertent leakage. In preparing use-dilutions and when applying them, personnel should control the operations to prevent exposure

of others and wear respiratory protection as necessary. Mutagenic potential has been attributed to ethylene oxide; toxic and hypersensitivity effects are well established for formaldehyde.

d. Radiation

The uses of UV irradiation carry the danger of burns to the cornea of the eyes and the skin of persons exposed for even a short time. Proper shielding should be maintained where irradiation treatment is used when personnel and laboratory animals are present. Guard against reflecting surfaces (e.g., polished stainless steel) occurring in line with the light source. In areas irradiated without shielding on special occasions or during off-duty hours, post the area with warning signs to prevent *unscheduled entry of personnel*.

#### F. Care and Use of Laboratory Animals

Special attention must be given to the humane treatment of all laboratory animals in accordance with the Animal Welfare Act of 1970. The implementing rules and regulations appear in the Code of Federal Regulations (CFR) Title 9, Chapter 1, Subchapter A, Parts 1, 2, and 3. Recommended provisions and practices that meet the requirement of the Act have been published by the U. S. Public Health Service.

Each laboratory should establish procedures to ensure the use of animals that are free of disease prejudicial to the proposed experiments and free from carriers of disease or vectors, such as ectoparasites, which endanger other experimental animals or personnel.

Animal caretakers must be well trained in the basic fundamentals of laboratory animal care. Appropriate training materials are available from a number of animal care associations or commercial organizations.

Animal caretakers, scientists, or others routinely exposed to infected animals, potentially contaminated equipment, and animal wastes should participate in preventive medical and medical surveillance programs of the institution involved.

## 1. Care and Handling of Infected Animals

Comprehensive reviews indicate that animals infected with a wide range of etiological agents are capable of shedding infectious microorganisms in the saliva, urine, or feces. In the absence of specific information to the contrary, all infected animals should be regarded as potential shedders. Procedures appropriate for the handling of infected animals are given below:

- a. Careful handling procedures should be employed to minimize the dissemination of dust from animal and cage refuse.
- b. Cages should be sterilized by autoclaving. Refuse, bowls, and watering devices should remain in the cage during sterilization.
- c. All watering devices should be of the "non-drip" type.
- d. Cages should be examined each morning and at each feeding time so that dead animals can be removed.
- e. Heavy gloves should be worn when feeding, watering, handling, or removing infected animals. Bare hands should NEVER be placed in the cage to move any object therein.
- f. When animals are to be injected with biohazardous material, the animal caretaker should wear protective gloves and the laboratory workers should wear surgeon's gloves. Animals should be properly restrained (e.g., use of squeeze cage for primate inoculation) or tranquilized to avoid accidents that might result in disseminating biohazardous material, as well as to prevent injury to the animal and to personnel.
- g. Animals exposed to biohazardous aerosols should be housed in ventilated cages, in gastight cabinet systems, or in rooms designed for protection of personnel by use of ventilated suits.

h. Animals inoculated by means other than by aerosols should be housed in equipment suitable for the level of risk involved.

i. Infected animals to be transferred between buildings should be placed in ventilated cages or other aerosol-proof containers.

j. The oversize canine teeth of large monkeys present a particular biting hazard; these are important in the potential transmission of naturally-occurring, and very dangerous, monkey virus infections. Such teeth should be blunted or surgically removed by a veterinarian.

k. Presently available epidemiological data indicate that many zoonotic diseases, including infectious hepatitis and tuberculosis, can be transmitted from nonhuman primates to man. Newly imported animals may be naturally infected with these or other infectious diseases, and persons in close contact with such animals may become infected. The inadvertent transmission of zoonotic diseases from the experimental animal to the animal caretaker should be protected against by the use of personal protective equipment or cage systems designed to contain infectious material at its point of origin. Information concerning the level of hazard associated with work with a wide range of etiological agents and the selection of personal protective equipment and ventilated cage systems can be found in numerous publications.

## 2. General Guidelines that Apply to Animal Room Maintenance

- a. Doors to animal rooms should be kept closed at all times, except for necessary entrance and exit.
- b. Unauthorized persons should not be permitted to enter animal rooms.
- c. A container of disinfectant, prepared fresh each day, should be kept in each animal room for disinfecting gloves and hands and for general decontamination even though no infectious animals are present. Hands, floors, walls, and cage racks should be washed with an approved disinfectant at the recommended strength as frequently as the supervisor directs.
- d. Floor drains in animal rooms, as well as floor drains throughout the building, should be flooded with water or disinfectant periodically to prevent backup of sewer gases.
- e. Shavings and other refuse on floors should not be washed down the floor drain, because such refuse clogs the sewer lines.
- f. An insect and rodent control program should be maintained in all animal rooms and in animal food storage areas.
- g. Special care should be taken to prevent live animals, especially mice, from finding their way into disposable trash.
- h. Specific instructions involving the housing, care, and maintenance of laboratory animals are available from numerous sources (see Section VI,F, "Reference Bibliography on Biological Safety").

### 3. Necropsy Rules for Infected Animals

- a. Necropsy of infected animals should be carried out by trained personnel in Biological Safety Cabinets.
- b. Surgeons' gowns should be worn over laboratory clothing during necropsies.
- c. Rubber gloves should be worn when performing necropsies.
- d. The fur of the animal should be wetted with a suitable disinfectant.
- e. Small animals should be pinned down or fastened on wood or metal in a metal tray.
- f. Upon completion of necropsy, all potentially biohazardous material should be placed in suitable containers and sterilized immediately.
- g. Contaminated instruments should be placed in a horizontal bath containing a suitable disinfectant.
- h. The inside of the Biological Safety Cabinets and other potentially contaminated surfaces should be disinfected with a suitable germicide.
- i. Grossly contaminated rubber gloves should be cleaned in disinfectant before removal from the hands, preparatory to sterilization.
- j. Dead animals should be placed in proper leak-proof containers, autoclaved, and properly tagged before being placed outside for removal and incineration.

## G. Biohazard Symbol and Its Use

A biological hazard symbol is used internationally to indicate the actual or potential presence of a biohazard and to identify equipment, containers, rooms, materials, experimental animals or combinations thereof that contain, or are contaminated with, viable hazardous agents. The symbol can be obtained commercially and placed upon a placard that is large enough for the symbol together with other appropriate information. The term "biohazard" for the purpose of this symbol is defined as "those infectious agents presenting a risk or potential risk to the well-being of man, either directly through his infection or indirectly through disruption of his environment."

The symbol is a fluorescent orange or an orange-red color. There is no requirement for the background color as long as there is sufficient contrast to permit the symbol to be clearly defined. The symbol shall be as prominent as practical, of a size consistent with the size of the equipment or material to which it is affixed, and easily seen from as many directions as possible.

The biohazard symbol is used or displayed only to signify the actual or potential presence of a biological hazard. Appropriate wording may be used in association with the symbol to indicate the nature or identity of the hazard, name of individual responsible for its control, precautionary information, etc., but never should this information be superimposed on the symbol.

Illustrations of the design and proportioning of the symbol and of the symbol used on an access control placard are shown on the following pages. The use of the biohazard symbol in recombinant DNA research is summarized in the table.



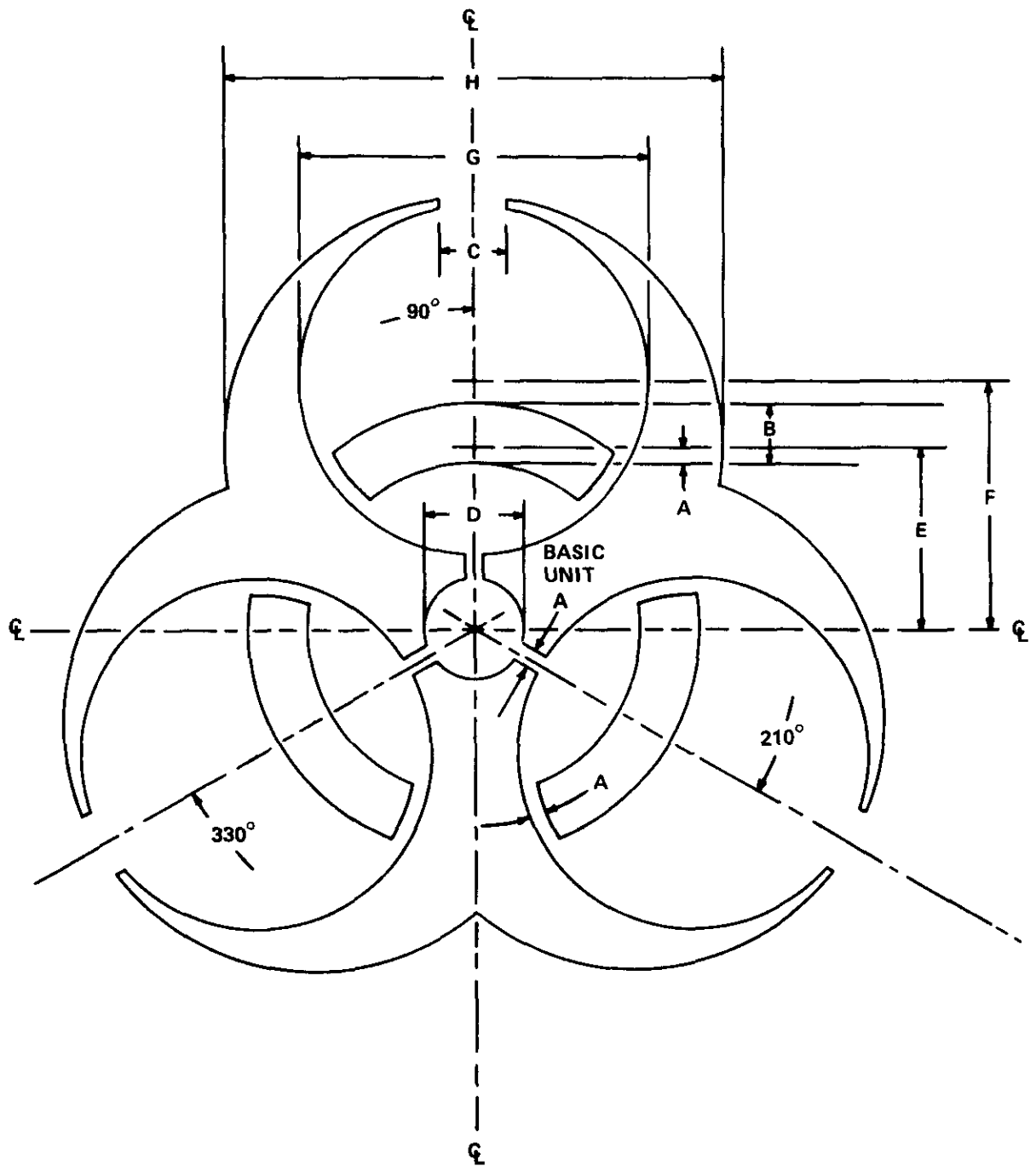

DIMENSION	A	B	C	D	E	F	G	H
UNITS	1	3½	4	6	11	15	21	30



**BIOHAZARD**

**ADMITTANCE TO AUTHORIZED PERSONNEL ONLY**

Hazard identity: \_\_\_\_\_

Responsible Investigator: \_\_\_\_\_

In case of emergency call:

Daytime phone \_\_\_\_\_ Home phone \_\_\_\_\_

**Authorization for entrance must be obtained from  
the Responsible Investigator named above.**

USE OF BIOHAZARD SYMBOL IN RECOMBINANT DNA RESEARCH

<u>PHYSICAL CONTAINMENT LEVEL</u>	<u>LABORATORY DOOR</u>	<u>ACCESS CONTROL OR CHANGE ROOM DOOR</u>	<u>FREEZERS AND REFRIGERATORS</u>
P1	--	--	--
P2	when experiments are in progress	--	when used to store agents <sup>1</sup>
P3	when experiments are in progress	where agents <sup>1</sup> are present	when used to store agents <sup>1</sup>
P4	where experiments are conducted	where agents <sup>1</sup> are present	when used to store agents <sup>1</sup>

<sup>1</sup>organisms containing recombinant DNA molecules

#### H. Protection of Vacuum System When Filtering Biohazardous Materials

The aspiration of tissue culture media from monolayer cultures and of supernatants from centrifuged samples into primary collection flasks is a common laboratory procedure. Protection should be provided against pulling biohazardous aerosols or overflow fluid into the vacuum system. This protection is provided by the use of an air filter in the line immediately leading into the house vacuum line and an overflow flask for liquids between the collection flask and the air filter.

Two techniques of protecting the vacuum system are shown in the figure. A cartridge-type filter provides an effective barrier to passage of aerosols into the house vacuum system. The filter has a capacity to remove airborne particles 450 nm (0.45  $\mu$ ) or larger in size. (Ultipor, DFA 3001 AXP5, from the Pall Corporation, Courtland, New York 13045 is an example of such a filter.)

For assembling either apparatus, flexible tubing is used of appropriate inside diameter for the flask and filter fittings and of sufficient wall thickness for the applied vacuum. Filter flasks of capacities from 250 to 4000 ml may be used for the overflow flask, depending on available space and amount of fluid that could be accidentally aspirated out of the collection flask.

The overflow flasks contain a disinfectant solution appropriate for the biohazardous material under study. It is essential that an antifoam, such as Dow Corning Antifoam A, be added to the overflow flask, since bubbling of air through the disinfectant probably will cause considerable foam which, if allowed to reach the filter, will shut off the vacuum.

If the filter becomes contaminated or requires changing, the filter and flask can be safely removed by clamping the line between filter and vacuum source. The filter and flask should be autoclaved before the filter is discarded. A new filter can then be installed and the assembly replaced.

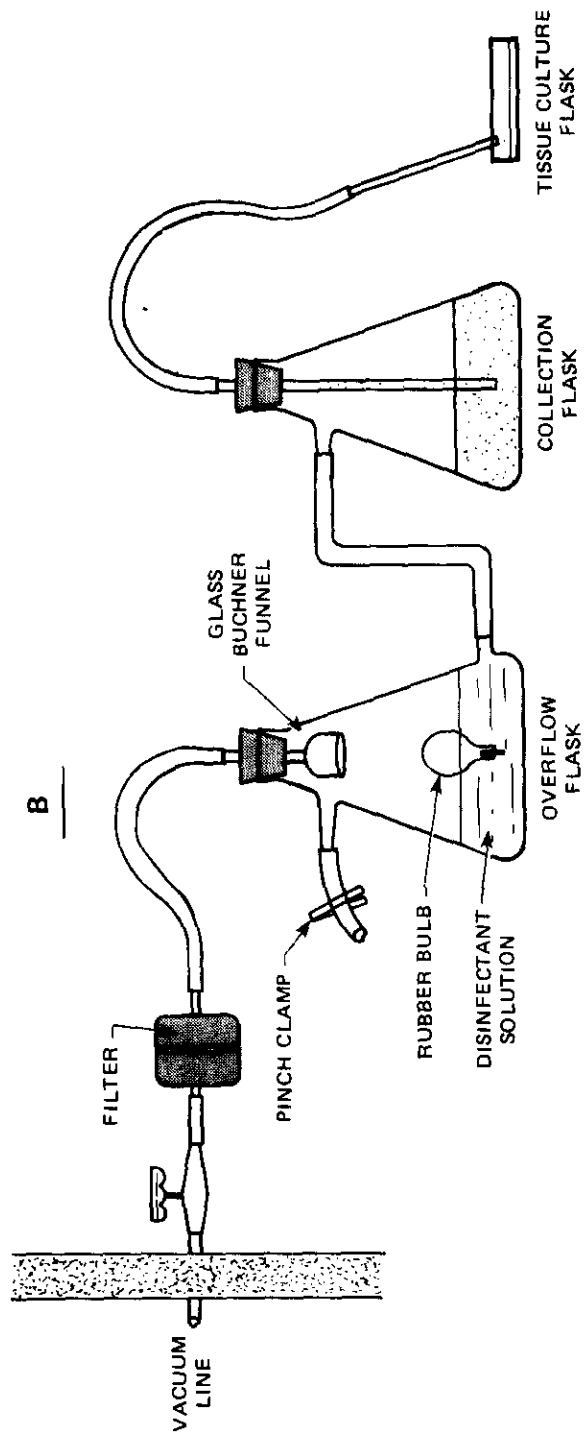
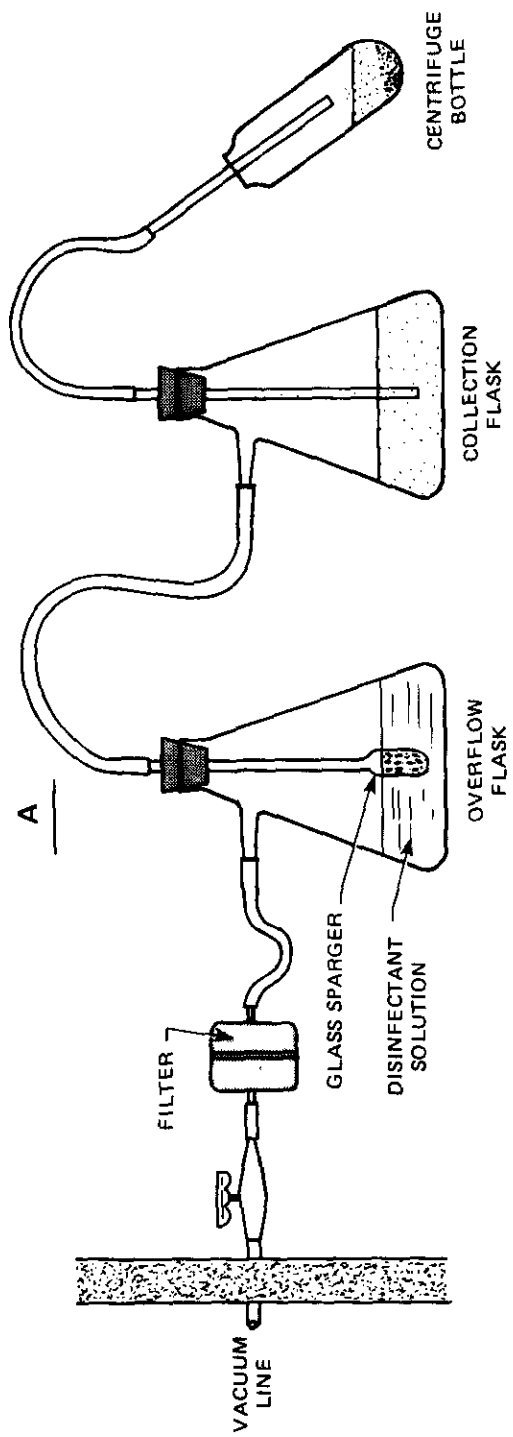

**TWO TECHNIQUES FOR PROTECTING VACUUM SYSTEM FROM CONTAMINATION**

The apparatus shown in A above is composed of two suction flasks, a filter, rubber stoppers, flexible vacuum tubing, glass tubing, and a small glass sparger. Various small fritted glass or ceramic spargers or gas dispersion tubes are commercially available. The coarse or medium porosity sparger assures that any aerosol passing through the collection flask is dispersed in small bubbles so that adequate contact is made with the disinfectant solutions.

The apparatus depicted in B has the feature of automatically shutting off the vacuum when the storage flask is full. It consists of a 1 L filter flask with a small glass Buchner funnel (15 ml capacity, 29 mm filter disk) inserted upside down in a No. 8 rubber stopper in the mouth of the flask. A hole, 2 cm in diameter, is cut into the bottom of the stopper with a cork borer and of sufficient depth that the filter disc is level with the bottom of the stopper. A 1/2 oz rubber bulb measuring 2 3/8 inches in length and 1 1/4 inches in diameter, with the end plugged with a solid glass rod measuring 1/4 inch in diameter and approximately 2 1/2 inches in length, is placed inside the flask.

If liquids enter the overflow flask, the rubber bulb rises until it presses against the mouth of the Buchner funnel and shuts off the vacuum. The entire unit is autoclavable, but the filter assembly should be thoroughly dried before reuse. A commercial version of this apparatus is available. (Vacuum Guard II, Model VG 201, Spectroderm International, Inc., Fairfax, VA 22030)

### III. Containment Equipment

#### A. The Biological Safety Cabinet

Biological Safety Cabinets are the principal equipment used to provide physical containment. They are used as primary barriers to prevent the escape of aerosols into the laboratory environment. This is an important function, because most laboratory techniques are known to produce inadvertent aerosols that can be readily inhaled by the laboratory worker. Certain cabinets can also protect the experiment from airborne contamination. The selection of a Biological Safety Cabinet is based on the potential hazard of the agent used in the experiment, the potential of the laboratory technique to produce aerosols, and the need to protect the experiment from airborne contamination.

Three types of Biological Safety Cabinets are used in the microbiological laboratory: the Class I cabinet, the Class II cabinet, and the Class III cabinet. The NIH Guidelines for Recombinant DNA Research require that either the Class I or Class II cabinet be used as the primary containment equipment when the P2 or P3 level of physical containment is specified. The Class III cabinet is required at the P4 level of physical containment. The description, capabilities, and limitations of these cabinets follow.

## APPLICATIONS OF BIOLOGICAL SAFETY CABINETS IN MICROBIOLOGICAL RESEARCH

Biological Safety Cabinet		Research uses/applications				
Type	Work opening	Face velocity ft/min	Oncogenic viruses <sup>a</sup>	Chemical carcinogens	Etiologic agents <sup>b</sup>	Recombinant DNA
Class I	Glove panel not in place	75	Low and moderate	No	CDC 1-3	P1-P3
	Glove panel in place without gloves	150	Low and moderate	Yes	CDC 1-3	P1-P3
	Glove panel in place with gloves	NA	Low and moderate	Yes	CDC 1-3	P1-P3
Class II Type A	Fixed height usually 10 inches	75, minimum	Low and moderate	No	CDC 1-3	P1-P3
Type B	Sliding sash provides opening adjustable from 8 to 20 inches for introduction and removal of equipment and materials. To obtain proper face velocity, experimentation should be done with 8-inch opening.	100 at 8-inch sash opening	Low and moderate	Yes in low difen and volatility	CDC 1-3	P1-P3
Class III	No direct opening. Access is through double-door sterilizer and decontaminant dunk bath.	NA	Low, moderate and high	Yes	CDC 1-4	P1-P4

<sup>a</sup> U.S. Department of Health, Education and Welfare, National Cancer Institute, Office of Research Safety. 1974. Safety standards for research involving oncogenic viruses. Bethesda, Md. 20014. DHEW Publication No. (NIH) 78-790.

<sup>b</sup> U.S. Department of Health, Education and Welfare, Public Health Service, Center for Disease Control. 1976. Classification of etiologic agents on the basis of hazard. Atlanta, Ga. 30333.



## 1. The Class I Biological Safety Cabinet

The Class I cabinet is a ventilated cabinet that may be used in three operational modes: with a full-width open front, with an installed front closure panel without gloves, and with an installed front closure panel equipped with arm length rubber gloves. Materials may be introduced and removed through the panel opening; and, if provided, through the hinged front view panel or a side UV air lock. Lights, vacuum, gas (do not provide if cabinet is to be operated sealed and with gloves installed), water, and drain can be provided. The materials of construction should be selected to withstand wear, corrosive action of gases and liquids, and decontaminants. Room air flowing into the cabinet prevents the escape of airborne contaminants from the cabinet work area. It flows across the work space, over and under a back wall baffle, out through a HEPA filter and blower in an overhead duct to the building air exhaust system or outdoors. When operated with a full-width open front, a minimum inward face velocity normal to the work opening of at least 75 feet per minute is required.

Protection is provided to the user and the environment, but not to the product (experiment). A wide range of activities is accommodated using equipment as varied as pipetting aids, burettes, pH meters, sonicators, shielded centrifuges, blenders, and lyophilizers. Chemical carcinogens and low levels of radioactive materials and volatile solvents can be used in Class I cabinets with minimum face velocities of 100 ft/min. When these materials are used in the Class I cabinet, a careful evaluation must be made to determine that concentrations do not reach dangerous levels or cause problems of decontamination of the cabinet.

The cabinet is a partial containment unit. Its primary barrier-function can be compromised by the pumping action of sudden withdrawal of the hands, the opening and closing of the room door, or rapid movements past the front of the cabinet. Aerosols created in large quantities, and forcefully, may overcome even higher face velocities. Also, the cabinet does not protect the experimenter's hands and arms from contact with hazardous materials. Such protection is dependent on technique and the use of gloves and other protective clothing.

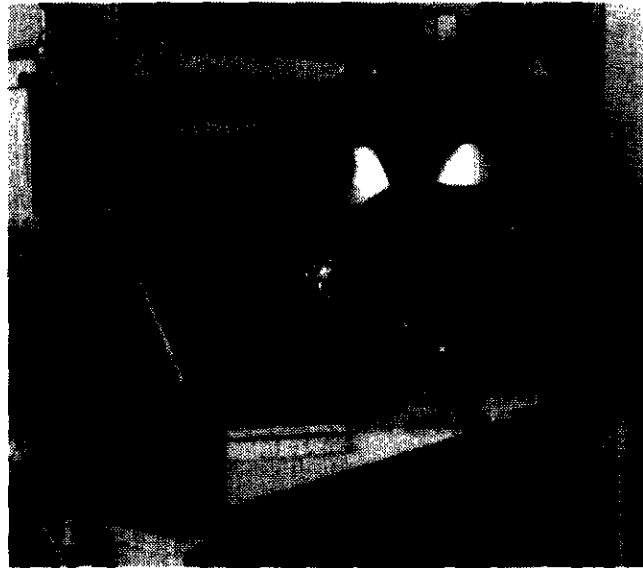
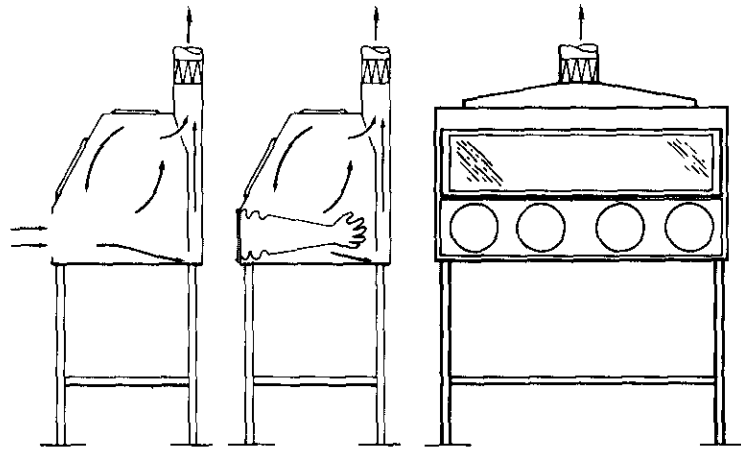

CLASS I CABINET

## 2. The Class II Biological Safety Cabinet

The Class II cabinet is commonly known as a laminar airflow Biological Safety Cabinet. Class II cabinets have a front opening for access to the work space and for introduction and removal of materials. Airborne contaminants in the cabinet are prevented from escaping across this opening by a curtain of air formed by (i) unfiltered air flowing from the room into the cabinet and (ii) HEPA filtered air supplied from an overhead grille in the cabinet. This curtain of air also prevents airborne contaminants in the room air from entering the work space of the cabinet across the front opening. The curtain of air is drawn through a grille at the forward edge of the work surface into a plenum below. Air from this plenum is HEPA filtered and recirculated through the overhead grille down into the cabinet. A portion of this filtered air is used to maintain the air curtain and the remainder passes down onto the work surface and is drawn out through grilles at the back edge of the work surface. The HEPA filtered air from the overhead grille flows in a uniform downward movement to minimize air turbulence. It is this air that provides and maintains a clean-air work environment. A percentage of air drawn through the front and back grilles of the work surface, which is equal to the flow of room air into the cabinet, is also filtered by HEPA filters and exhausted from the cabinet.

The selection of utility services and materials of construction are similar to those for Class I cabinets.

There are two types of Class II cabinets, A and B. These differ principally as to:

- vertical dimension of the front opening
- proportion of air recirculated
- velocity of airflow to work surface
- manner of discharge of exhaust air
- whether contaminated air plenums are under positive pressure.

The type A cabinet has a fixed front access opening. The inward face velocity through the front opening is at least 75 ft/min. Contaminated air plenums are normally operated at positive pressure. The cabinet

operates with a high percentage (approximately 70%) of recirculated air. The type A cabinets can be operated with recirculation of the filtered exhaust air to the room in which they are located. This minimizes extra demand on supply and exhaust air systems unless the buildup of heat and odor from the recirculated exhaust air requires otherwise.

Type B cabinets do not recirculate their exhaust air to the room. They have a vertical sliding sash rather than the fixed opening of the type A. Inward air velocity of 100 ft/min is attained at an 8-inch sash opening. The cabinet operates with a low percentage (approximately 30%) of recirculated air.

Type A and B cabinets are partial containment units with the same limitations as Class I cabinets. These cabinets provide protection to the user, environment, and product (experiment). Activities are accommodated that use pipetting aids, burettes, pH meters, sonicators, blenders, lyophilizers, and shielded centrifuges. The type B cabinets can be used with dilute preparations of chemical carcinogens, of low-level radioactive materials, and of volatile solvents when the face velocity of 100 ft/min is maintained. When these materials are used, however, a careful evaluation must be made to determine that concentrations do not reach dangerous levels or cause problems of decontamination of the cabinets. The type A cabinets cannot be used with toxic, explosive, flammable, or radioactive substances because of the high percentage of recirculated air.

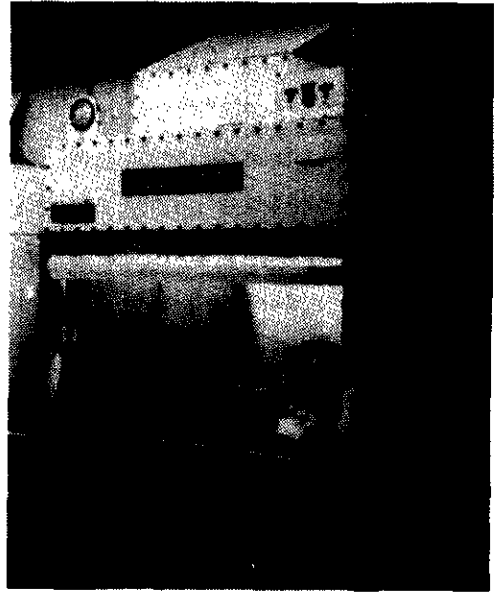
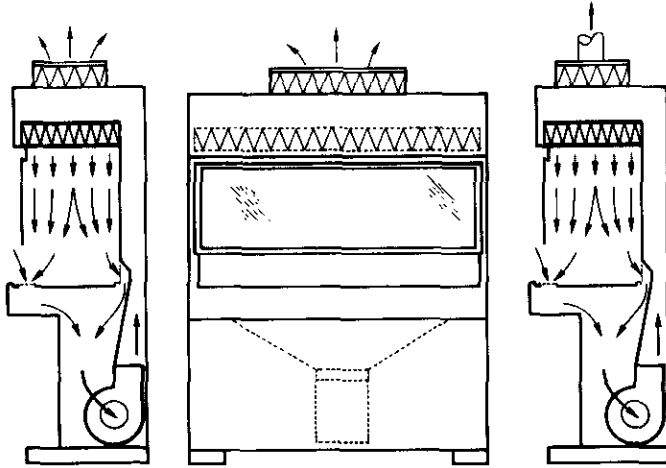

Type A

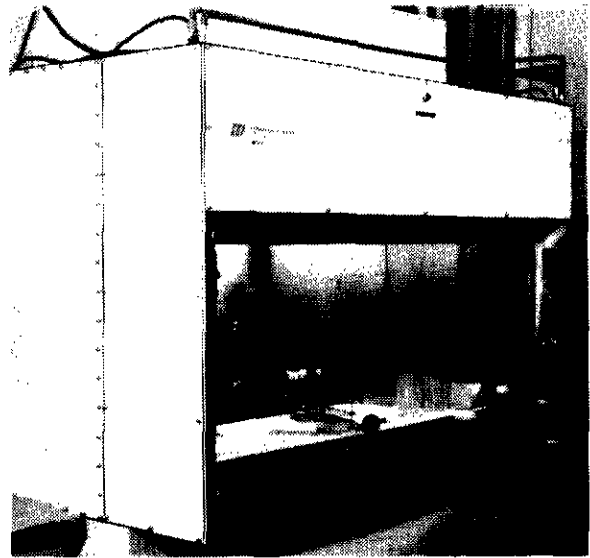
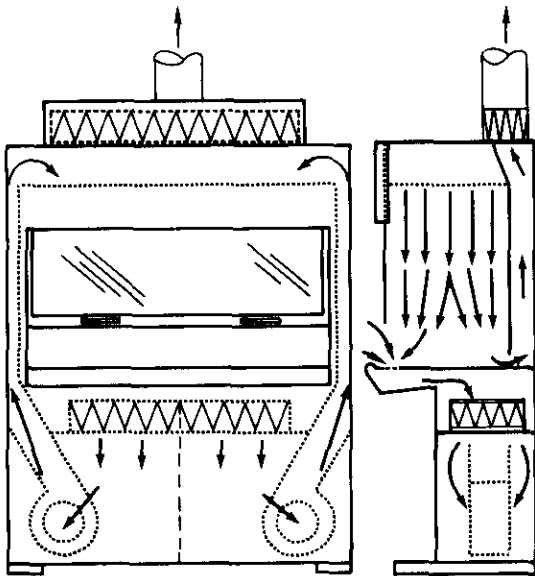

Type B

CLASS II CABINETS

### 3. The Class III Biological Safety Cabinet

The Class III cabinet is a totally enclosed ventilated cabinet of gastight construction. Operations within the Class III cabinet are conducted through attached rubber gloves. When in use, the Class III cabinet is maintained under negative air pressure of at least 0.5 inches water gage. Supply air is drawn into the cabinet through HEPA filters. The cabinet exhaust air is filtered by two HEPA filters installed in series or one HEPA filter and an incinerator. The exhaust fan for the Class III cabinet is generally separate from the exhaust fans of the facility ventilation system.

Materials are introduced and removed through attached double-door sterilizers and dunk baths with liquid disinfectants. The usual utility services can be provided, but not gas. Liquid wastes go to a holding tank for appropriate decontamination before release into "common" sewage lines. Stainless steel is the usual construction material. Modular designs provide for inclusion of refrigerator, incubator, deep freeze, centrifuge, animal holding, and other special cabinet units.

The Class III cabinet provides the highest level of personnel and environmental protection. Protection is also provided to the product (experiment). Most laboratory activities can be accommodated: the usual cultivation of microorganisms, fertile eggs, tissue cells; microscopy, serology; animal dissections and injections; experimental aerosol exposures; various physical measurements; and many others--on small- to large-scale. Selected gaseous atmospheres can be maintained at desired humidity and temperature conditions.

The Class III cabinet protection can be compromised by puncture of the gloves or accidents creating positive pressure in the cabinet. Flammable solvents should not be used in these cabinets unless a careful evaluation has been made to determine that concentrations do not reach dangerous levels. When required and determined safe, these materials should only be introduced into the system in closed, nonbreakable containers. These materials should not be stored in the cabinet. Electric heaters are preferred over portable, canned-gas heaters. Flammable gas should not be piped to the units.

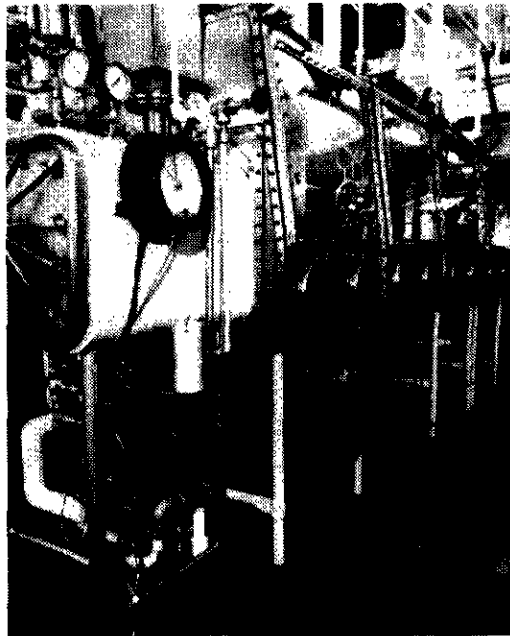
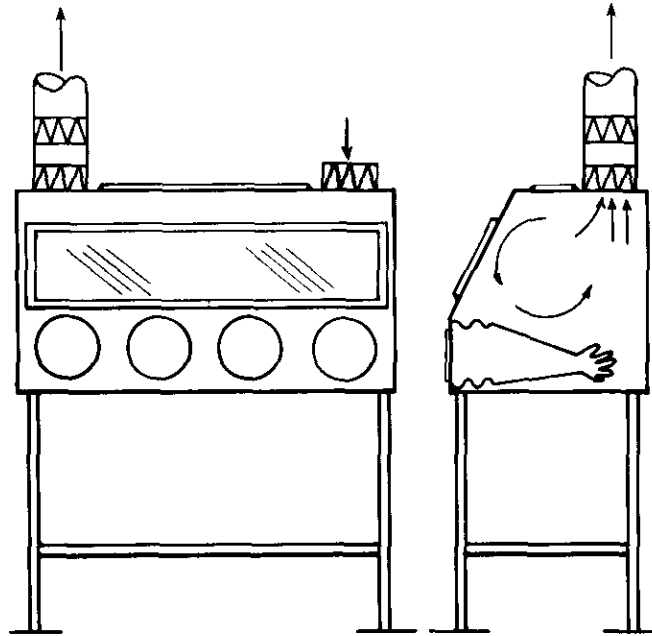

CLASS III CABINET

## B. Certification Procedures

The capability of biological safety cabinets to protect personnel and the environment from exposures to potentially hazardous aerosols is dependent on both the ability of the laboratory worker to use the cabinet properly and the adequate functioning of the cabinet itself. A biological safety cabinet should never be used to contain hazardous materials unless it has been demonstrated to meet certain minimum safety specifications. These specifications are summarized in the table on the next page.

Procedures for certifying the minimum safety specifications of biological safety cabinets are described below. The safety specifications should be certified (i) after a new cabinet has been purchased and installed, but before it is used, (ii) after it has been moved or relocated, and (iii) at least annually.

The certification procedures for Class II cabinets are those recommended by the National Sanitation Foundation in their Standard 49, "Class II (Laminar Flow) Biological Cabinetry." The "NIH Guidelines for Recombinant DNA Research" require that Class II biological safety cabinets conform to all performance requirements specified in Standard 49. Nevertheless, cabinets that have been certified by the National Sanitation Foundation must also be shown to meet the minimum safety specifications once the cabinets have been installed in a laboratory. This demonstration is part of the institutional certification requirement specified by NIH.



**MINIMUM PERFORMANCE SPECIFICATIONS OF BIOLOGICAL SAFETY CABINETS**

<u>Cabinet</u>	<u>Face velocity, fpm</u>	<u>Velocity profile</u>	<u>Negative pressure, inches, w.g.</u>	<u>Leak tightness</u>	<u>Exhaust filter efficiency</u>
Class I - Open front	75	NA	NA	NA	99.97% for 0.3 $\mu$ m particles
Class I - Front panel without gloves	150	NA	NA	NA	"
Class I - Front panel with gloves	NA	NA	$\Delta p > 0.5$	NA	"
Class II - Type A	75	a	NA	Leak rate $< 1 \times 10^{-4}$ cc/sec at 2" w.g. pressure	"
Class II - Type B	100	a	NA	NA	"
Class III	NA	NA	$\Delta p > 0.5$	Leak rate $< 1 \times 10^{-5}$ cc/sec at 3" w.g. pressure	b

a) Dependent on National Sanitation Foundation (NSF) certification in accordance with NSF Standard 49.

b) Both HEPA filters must be certified to have a filtration efficiency of 99.97% for 0.3  $\mu$ m particles. When an incinerator is used in lieu of the second HEPA filter, the incinerator must be capable of destroying all spores of *Bacillus subtilis* when challenged at a concentration of  $10^5$  spores per cubic foot.

1. Certification of the Face Velocity of the Class I Cabinet

a. Equipment Required

A thermoanemometer with a sensitivity of  $\pm 2$  lfm or 3 percent of the indicated velocity shall be used.

b. Test Procedure

(1) Take air velocity measurements at the midpoint height approximately one inch behind the vertical plane of the front work access opening.

(2) The individual velocity measurements shall be taken every four inches across the width of the front work access opening but no closer than four inches from edges of the work opening.

c. Test Criterion

The average face velocity through the work access opening shall be at least 75 lfm with no single measurement less than 60 lfm.

2. Certification of the Face Velocity of the Class II, Type A Cabinet

This test is performed to determine the calculated face velocity of the supply air through the work access opening.

a. Equipment Required

A thermoanemometer with a sensitivity of  $\pm 2$  lfp/m or 3 percent of the indicated velocity shall be used.

b. Procedure

(1) The air velocity measurements shall be taken at multiple points across the exhaust filter face on a grid with the points approximately four inches apart and four inches above the face of the filter. The minimum number of air velocity readings shall be nine for each square foot of exhaust filter surface. Using the average air velocity, the exhaust air quantity (cfm) shall be calculated.

(2) Calculate the face velocity of the supply air entering the work access opening by dividing the exhaust airflow quantity by the work access opening area.

c. Test Criterion

The calculated face velocity through the work access opening of the cabinet shall not be less than 75 lfp/m.

3. Certification of the Face Velocity of the Class II, Type B Cabinet

a. Equipment Required

A thermoanemometer with a sensitivity of  $\pm 2$  lfm or 3 percent of the indicated velocity shall be used.

b. Test Procedure

(1) Turn off fans that recirculate air within the cabinet.

(2) Close sliding sash to 8-inch opening position.

(3) Take air velocity measurements at the midpoint height approximately one inch behind the vertical plane of the front work access opening.

(4) The indicated velocity measurements shall be taken every four inches across the width of the front work access opening but no closer than four inches from edges of the work opening.

c. Test Criterion

The average face velocity through the work access opening shall be at least 100 lfm with no single measurement less than 75 lfm.

#### 4. Certification of the Velocity Profile of the Class II Cabinet

This test is performed to measure the velocity of the air that is recirculated through the overhead grille down into the cabinet.

##### a. Equipment Required

A thermoanemometer with a sensitivity of  $\pm 2$  lpm or 3 percent of the indicated velocity shall be used. Provide stand and clamp to hold the probe.

##### b. Test Procedure

Measure the air velocity in the work space at multiple points across the work space below the filters on a grid scale to give approximately nine readings per square foot in the horizontal plane defined by the bottom edge of the window frame. Air velocity readings shall be taken at least six inches away from the perimeter walls of the work area. The thermoanemometer probe shall be held by a clamp attached to a stand to eliminate hand movement.

##### c. Test Criterion

The downward airflow velocity profile through the cross section of the unobstructed work area of the cabinet shall meet the velocity profile as established during the certification process by NSF in accordance with NSF Standard 49. The velocity of any single point shall not be below 45 lpm. For those cabinets manufactured prior to adoption of Standard 49, the average downward airflow velocity shall be 80 lpm with individual point readings not varying more than  $\pm 20$  percent of the average.

5. Certification of the Leak Tightness of the Class II, Type A Cabinet

This is to be performed on all contaminated air plenums of Class II cabinets that are under positive pressure with respect to the laboratory room. This test is performed to determine if the exterior joints made by welding, gasketing, penetrations or sealant seams are free of leaks that might release potentially hazardous materials into the room environment.

a. Equipment Required

(1) Industrial type halogen leak detector, General Electric Ferret, G. E. Catalog No. 50-420 810 HFJK or equal.

(2) Calibrated leak standard, G. E. LS-20, Catalog No. 50-420 701 AAAMI ( $0-10 \times 10^{-7}$  cc/sec) or equal.

(3) Tank(s) of halide gas (dichlorodifluoromethane).

(4) Manometer, magnehelic gage or U-tube water column (graduated to read in inches water gage).

(5) Gasketed rigid steel plate, four furniture type pipe clamps, four pieces of 4 x 4 x 8' lumber, and assorted tools.

b. Test Procedure

(1) Prepare the test area of the cabinet as a closed system by sealing the front window opening, exhaust port, removable panels, and all other penetrations.

(2) Attach a manometer or pressure gage to the test area to indicate the interior pressure.

(3) Pressurize the test area with air to a reading of two inches water gage. If the test area holds this pressure without loss for 30 minutes, release pressure. If the test area does not hold this pressure, examine for gross leaks with soap solution (1:10 dilution of Ajax liquid dishwashing detergent or equal).

(4) The room in which the testing will be performed shall be free of halogenated compounds, and air movements shall be kept to a minimum. No smoking should take place in the test room.

(5) Pressurize the cabinet test area to two inches water gage pressure using halide gas (dichlorodifluoromethane).

(6) Adjust the halogen leak detector in accordance with the manufacturer's instructions to a sensitivity setting of  $4.5 \times 10^{-7}$  cc/sec.

(7) Move the probe over the seams, joints, utility penetrations, panel gaskets, and other areas of possible leakage. The nozzle of the detector probe shall be held at the surface of the test area so as not to jar the instrument and should be moved over the surface at the rate of about one inch per second, keeping the probe 1/4 to 1/2 inch away from the surface.

c. Test Criterion

Halogen leakage shall not exceed a leak rate of  $1 \times 10^{-4}$  cc/sec at two inches water gage pressure.

The acceptance criterion is based on a halogen leak, which would occur if the cabinet plenum contained 100% halide gas. Since pressurizing the plenum to two inches water gage pressure using halide gas creates a concentration of only 0.5% halide gas, the detector is operated at a sensitivity of  $4.5 \times 10^{-7}$  cc/sec to account for the dilution of the halide gas.

## 6. Certification of Leak Tightness of the Class III Cabinet Systems

### a. Equipment Required

- (1) Industrial type halogen leak detector, General Electric Ferret, G. E. Catalog No. 50-420 810 HFJK or equal.
- (2) Calibrated leak standard, G. E. LS-20, Catalog No. 50-420 701 AAAMI (0-10 x 10<sup>-7</sup> cc/sec) or equal.
- (3) Tank(s) of halide gas (dichlorodifluoromethane).
- (4) Manometer, magnehelic gage or U-tube water column (graduated to read in inches water gage).
- (5) Soap Solution (1:10 dilution of Ajax liquid dishwashing detergent or equal), spray bottles and brushes.
- (6) Glove opening cover plates, silicone rubber sheet gasketing, rigid steel plates, C-type clamps, duct tape, and assorted tools.

### b. Test Procedure

- (1) Seal all air inlets and outlets of the cabinet system: Fill with water all deep seal water traps in the cabinet system's waste water drain system. Fill the dunk tank(s) with water. Close all valves of the cabinet system (e.g., waste water drain, vents, air, vacuum, steam, water, etc.). Install gloves or attach and tighten all gasketed glove opening cover plates to the cabinet system. Close and seal the outer sterilizer door(s) located in the system.
- (2) Tape all glass windows with masking tape at 12-inch intervals to prevent possible breakage.
- (3) Provide access means to pressurize the cabinet with air and halide gas. Access may be by hoses passed through the dunk tanks or utility service piping.
- (4) Attach a manometer, magnehelic gage or U-tube water column to the cabinet system in a manner that indicates the differential pressure between the cabinet system and the room.
- (5) Pressurize the cabinet system or section of the system to be tested with air to three-inch water gage and hold the system under



pressure for 30 minutes. If pressure is lost rapidly, check the system for gross leaks. Gross leaks can be found by sound and feel. Repair the gross leaks.

(6) Once the gross leaks have been repaired, smaller leaks can be detected by soap solution testing. Prepare a 1:10 dilution of liquid dishwashing detergent such as Ajax or equal. Pressurize the cabinet system to three inches water gage with air and maintain this pressure. Carefully apply soap solution to all joints, window seals, and penetrations. Repair all leaks indicated by the formation of bubbles. Retest all repaired leaks.

(7) After soap solution testing, thoroughly clean all surfaces to remove trace quantities of the soap solution.

(8) Prepare the Halogen Leak Detector in accordance with the manufacturer's specifications.

(9) Calibrate the leak detector according to the manufacturer's instructions. Use a calibrated halide gas leak standard such as the LS-20. Adjust the leak standard to indicate a leak rate of  $1 \times 10^{-7}$  cc/sec. Using the leak standard, adjust the sensitivity of the instrument to indicate a leak rate of  $1 \times 10^{-7}$  cc/sec on the 0-10 scale. [During the leak testing process, check the sensing instrument against the calibrated leak standard frequently. Excessive exposure of the filament to dichlorodifluoromethane can cause corrosion and desensitization of the filament.]

(10) Before halide gas is added to the system, a complete background scan should be made. The area in which the leak testing is performed must be free of extraneous sources of halogenated compounds, because they will interfere with the sensitivity of the test. Such sources of background could originate from indiscriminate dumping of refrigerant charges, leaky lines, degreasers using halogenated solvents, paint fumes, automobile exhaust, cigarette and pipe smoke, ethylene oxide cylinders and aerosol cans using halogenated gases as the propellant and insulation. Air turbulence should be eliminated to prevent the dilution of any escaping test gas. Background interference may be controlled by maintaining the test

area at a positive air pressure with respect to the surrounding area. This would indicate if the space is free of halogenated compounds or other interfering material. Scan the surfaces of the Class III cabinet system, such as welded seams, gasketed areas, pipe penetrations, valves, windows, control penetrations, electrical fittings and conduits, drive shafts and seals, sterilizer attachment(s), drain lines, vent lines, filter housing, etc. The scanning rate with probe is approximately one inch per second. Mark areas of background interference. The areas of background should be eliminated, if possible.

(11) After the space has been shown to be free of background interference, release into the cabinet system atmosphere, one ounce of the halide gas for each 30 cubic feet of the cabinet system volume. This amount of halide gas will create a concentration of approximately 1% halide gas by volume. After the halide gas has been introduced into the system, bring the total pressure to 3.0" water gage using air. Set the leak detector on the scale that reads  $1 \times 10^{-7}$  cc/sec. (Note: The filament of the leak detector operates at a high temperature and voltage. The following safety precautions must be followed: (i) Never use the leak detector in an environment that contains an explosive vapor. (ii) Never test in vents or enclosed spaces, such as bearing housings, oil tanks or piping, without first testing the area with an explosion meter. (iii) The detector must be grounded.)

(12) Scan all joints, window seals and penetrations. The leak detector probe is held close to the surface to be tested (but not touching) and it should be moved at approximately one inch per second. Mark all points of leakage. Make repairs, retest for background, and then add halide gas and retest. All components of the Class III system, including sterilizers, attached centrifuges, etc., must be tested in this manner.

(13) Continue testing in this manner until the cabinet(s) is leak tight. (Under prolonged testing procedures, gasket material may become saturated with halide gas. Subsequent off-gasing may cause interference.)

c. Test Criterion

Halogen leakage shall not exceed a leak rate of  $1 \times 10^{-5}$  cc/sec at three inches water gage pressure. The acceptance criterion is based on a halogen leak that would occur if the cabinet system contained 100% halide gas. Since the test concentration of halide gas is 1%, the detector is operated at a sensitivity of  $1 \times 10^{-7}$  cc/sec to account for the dilution of the test gas.

## 7. Leak Testing of High-Efficiency Particulate Air Filters (HEPA)

This test is performed to determine the filtration efficiency of the HEPA filters and the integrity of the filter housings and the filter mounting frames.

### a. Equipment Required

(1) Aerosol Photometer with either linear or logarithmic scale. An instrument of this type shall have a threshold sensitivity of at least  $10^{-3}$  micrograms/liter of air for polydispersed liquid aerosol of dioctyl phthalate (DOP) particles and a capacity for measuring an 80-120 micrograms/liter concentration. The DOP polydispersed liquid aerosol has an approximate light-scattering mean droplet-size distribution, as follows:

99+%	less than	3.0 $\mu\text{m}$
50+%	"	" 0.7 $\mu\text{m}$
10+%	"	" 0.4 $\mu\text{m}$

The instrument shall sample air at a flow rate of one cfm. The aerosol photometer shall be factory calibrated once each calendar year according to the manufacturer's recommended calibration procedures. (Refer to ANSI Standard, N 101.1-1972, Efficiency Testing of Air-Cleaning Systems Containing Devices for Removal of Particles, or its current edition.)

(2) DOP Generator with Laskin Nozzle(s). Liquid DOP is aerosolized by flowing air through the liquid.

(3) Air source to generator. It shall provide a pressure of  $20 \pm 2$  psig and a minimum free airflow through the generator of one cfm/nozzle.

(4) Auxiliary blower, hose and connection fixtures.

(5) Sealant material (RTV type) and closed cell neoprene gasket material.

(6) Various wrenches and hand tools.

### b. Test Procedure

(1) Remove the hardware located downstream of the HEPA filter(s). For HEPA filters that cannot be scan tested in their own

housing, remove the filter and install it in a test assembly and follow normal scan testing procedures.

(2) Airflow through the HEPA filters when testing Class II cabinets should be at normal operating velocities. All other HEPA filters will be tested at 20% of rated filter airflow.

(3) Position the DOP generator to introduce air-generated smoke into the area upstream of the filter. Adjust the generator pressure to  $20 \pm 2$  psig with a minimum free airflow through the generator equaling one cfm per nozzle.

(4) Turn on the aerosol photometer and calibrate according to the manufacturer's instructions.

(5) Measure the upstream concentration of DOP.

(a) For linear readout photometers - (graduated 0-100). Use at least one Laskin nozzle per 500 cfm airflow or increment thereof and adjust the instrument to read 100%.

(b) For logarithmic readout photometers - The upstream concentration shall be adjusted, using the instrument calibration curve, to give a concentration of  $1 \times 10^4$  particles above the minimum sensitivity of the photometer. (REF: Federal Standard 209B, para. 50.1)

(6) Filter Leak Test

(a) Scanning Method

Holding the photometer probe approximately one inch from the filter face on the downstream side, scan the entire surface area and perimeter (filter gasket-frame-housing area) of the filter in slightly overlapping strokes at a traverse rate of not more than ten feet per minute. The photometer sample rate shall equal  $1 \pm 10\%$  cfm. When leakage is indicated, repair leaks in the HEPA filter media with silicone RTV sealant. Repair leaks found at the gasket-frame area with laboratory stopcock (silicone) grease. Replace the gasket, if necessary. Retest filter after repair of leaks is completed.

(b) Probe Method

For HEPA filters that cannot be scan tested in-place,

connect auxiliary blower and hose upstream of HEPA filter and introduce air-generated DOP. Insert the photometer probe into the air duct downstream of the HEPA filter installation and measure for total leakage. If the leakage is above the acceptable limit listed in test criteria, retighten filter clamps and retest. If this does not solve the leakage problem, remove the filter and insert the HEPA filter into a test assembly. Scan test the filter face, housing and gasket area. Repair all leaks, and retest. Install filter in its housing and retest.

c. Test Criterion

A HEPA filter and its frame and housing are considered acceptable when no detectable leaks are observed. A detectable leak is defined as either a reading of 0.01% or greater for linear readout photometers or a reading of one scale division or greater for logarithmic readout photometers. Refer to calibration curve for the instrument in use. Generally, 0.01% is one full-scale division above the minimum sensitivity of the logarithmic photometer.

## 8. Certification of the Operational Negative Air Pressure in the Class III Biological Safety Cabinet System

### a. Equipment Required

(1) Magnehelic gages with scale divisions calibrated to read in tenths of an inch water gage installed on Class III cabinets to measure the differential pressure between the cabinet system and the room.

(2) Remote and local alarm sensors to detect a decrease in the cabinet system negative air pressure.

(3) Inclined Manometer (0-1 inch water gage).

### b. Test Procedure

(1) Verify that all gages have an accuracy of  $\pm 2\%$  for full-scale readings at 70° F. These gages may be tested by comparison with a liquid-filled inclined manometer.

(2) Balance the quantity of air to be exhausted from the Class III cabinet system. This can be determined by measuring the exhaust air quantity in the cabinet system's main exhaust duct. The minimum air change rate within the cabinet system should be ten air changes per hour.

(3) Verify that the magnehelic gages indicate a negative air pressure of at least 0.5 inches water gage once the cabinet system is balanced and the system is operational.

(4) Adjust the remote and local alarm sensors according to the manufacturer's directions to sense an operational negative air pressure drop below 0.25" water gage. The sensors should have a delayed response to allow for a negative air pressure drop when the operator removes his hands from the gloves.

### c. Test Criterion

The negative pressure within the cabinet system is acceptable when at least a 0.5 inch water gage negative pressure with respect to the room is maintained at the proper operating air balance.

#### IV. SPECIAL LABORATORY DESIGN

Recombinant DNA research requiring physical containment at the P1 and P2 levels can be conducted in conventional laboratory facilities that do not require special design considerations. Experiments requiring P3 or P4 physical containment must be conducted in facilities which meet certain minimum design requirements specified in the Guidelines. This section provides further guidance for the design and certification of such facilities.



#### A. The P3 Facility

The P3 facility has special engineering features that make it possible for laboratory workers to handle moderately hazardous materials without endangering themselves, other resident personnel, the community, or the environment.

The P3 facility may be a single laboratory module or a complex of modules within a building or an entire building. The P3 facility is separated by a controlled access zone from areas open to the public and other laboratory persons who do not work within the P3 facility. Various arrangements of space can be used to achieve separation as shown in alternatives a, b, and c presented on the following page.

The ventilation system supporting the containment facility is capable of controlling air movement. The direction of airflow is to be from spaces of lower contamination potential to spaces of higher contamination potential. The system is balanced so that there is infiltration of air into each laboratory module or animal room from the adjacent corridors. It is recommended that the infiltration rate be at least 50 cubic feet per minute. The P3 facility may be served by the same supply and exhaust air system that serves areas outside the P3 facility, provided the exhaust air is not recirculated and air balance can be maintained. Air may be recirculated if the air is filtered by HEPA filters. The exhaust air from P3 facilities is discharged to the outdoors clear of occupied buildings and supply air intakes. This is usually accomplished by locating the exhaust stacks on the roof and exhausting upward at relatively high velocity (e.g., >2500 fpm). The general exhaust air can be discharged to the outdoors without filtration or other treatment.

Each laboratory module of the P3 facility should be capable of accommodating a Biological Safety Cabinet. The treated cabinet exhaust air may be discharged directly to the laboratory module. It is recommended, however, that the treated cabinet exhaust air be discharged directly to the outdoors through an individual duct and exhaust fan or through the general exhaust system of the P3 facility. In the latter case, it is important that the exhaust system be designed and operated

Layout A illustrates three approaches to separating a single module P3 facility from a common-use corridor.

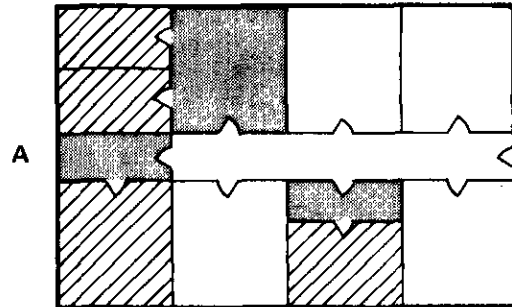

Layout B depicts a corridor as the access zone. This approach is acceptable but undesirable unless strict access control can be ensured.

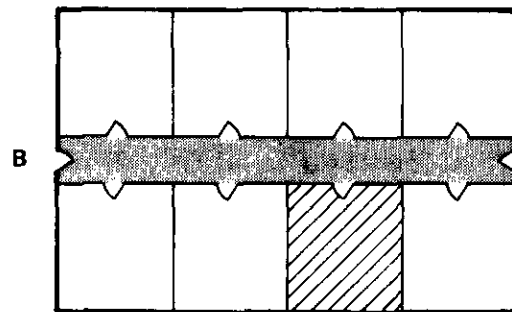

Layout C shows the access zone as a change room and shower facility. Access to the P3 facility is by passage from the clean clothing change room through the drying room, shower room, and "contaminated" clothing change room. This traverse is reversed for egress. In this example, the airlocks are used only for the passage of equipment, materials, or supplies into the P3 facility.

The change room and shower facility arrangement provides the greatest access control of any of the examples. This arrangement is recommended when the P3 facility comprises a number of laboratory modules or animal rooms.

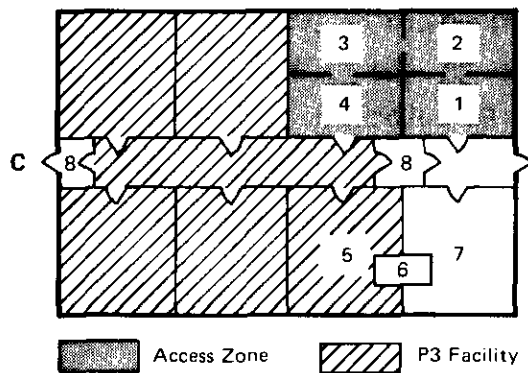

- 1 Clean Clothing Change Room
- 2 Drying Room
- 3 Shower Room
- 4 Contaminated Clothing Change Room
- 5 Contaminated Waste Handling Room
- 6 Double Door Autoclave
- 7 Washing Room
- 8 Air Lock

### REPRESENTATIVE LAYOUT PLANS FOR ACCESS CONTROL TO P3 FACILITY

in a manner that avoids interference with the air balance of the P3 facility and the Biological Safety Cabinet. Pressurization of the exhaust duct must be avoided.

The surface finishes of walls, floors, and ceilings should be resistant to liquid penetration and be readily cleanable. If windows are provided, they should be sealed shut in position. If false ceilings are installed to conceal air ducts and utility distribution lines, they should be constructed of plaster or dry-wall. All ceiling joints should be taped and sealed before the surface finish is applied. The recommended floor surface is a monolithic-type covering that is free of seams or cracks. However, floor tiles with seams sealed by waxing provide an acceptable floor surface.

The openings in walls, floors and ceilings through which utility services and air ducts penetrate should be sealed to permit space decontamination. These openings can be effectively sealed by the application of a liquid silicone plastic.

A foot, elbow, or automatically operated hand washing facility should be provided near the exit area of each primary laboratory module. All doors of the P3 facility should be self-closing.

An autoclave should be located within the P3 facility. With appropriate procedural controls, it is possible to locate the autoclave outside of the P3 facility, provided it is located within the same building.

## B. The P4 Facility

The design objective of the P4 facility is to create a facility that will allow the safe conduct of research involving biological agents that may present a high potential hazard to the laboratory worker, or that may cause serious epidemic disease. The distinguishing characteristic of the P4 facility is the provision for secondary barriers that prevent the escape of hazardous materials to the environment. The secondary barriers serve to isolate the laboratory area from the surrounding environment.

The secondary barriers include:

- Monolithic walls, floors, and ceilings in which all penetrations such as air ducts, electrical conduits, and utility pipes, are sealed to ensure the physical isolation of the laboratory area
- Air locks through which supplies and materials can be brought safely into the facility
- Contiguous clothing change rooms and showers through which personnel enter the facility and exit from it
- Double-door autoclaves to sterilize and safely remove wastes and other materials from the facility
- Biowaste treatment system to sterilize liquid wastes
- Separate ventilation system that maintains negative air pressures and directional airflow within the facility
- Treatment system to decontaminate exhaust air before dispersed into the atmosphere.

Although the P4 facility is generally a separate building, it may be constructed as an isolated area within a building. The perimeter wall partitions of the facility should be installed the full height from finished floor to the under surface of the floor or roof above. If windows are installed in the perimeter partitions, they should be fixed shut and the frames should be thoroughly caulked with sealant. The window glass should be safety glass. Perimeter doors should be insect and rodent proof. Wall, floor, and ceiling construction joints, utility pipes and duct penetrations, and electrical conduits and other passages should be sealed to assure isolation of the laboratory environment. The surface finishes should be selected on the basis of their ability to provide a monolithic surface barrier. Epoxy, phenolic, and polyurethane finishes have proved satisfactory for this purpose.

The clothing change rooms and showers are contiguous to the perimeter structure of the facility. They are generally arranged so that the clean clothing change area is separated from the laboratory zone by an air lock or shower area. Personnel egress from the laboratory zone must be through the shower area to the clean clothing change room. Air locks for movement of materials, supplies, and equipment into the facility are also a part of the perimeter structure. The air lock doors should be electrically interlocked so that pressure differentials within the facility can be maintained when the air locks are in use. The double-door autoclave is located so that either the interior or exterior door frame is sealed to the perimeter barrier wall. It is preferable to make the interior door frame contiguous with the barrier wall so that autoclave maintenance can be performed outside the laboratory zone.

The P4 facility is ventilated by its own supply and exhaust air mechanical ventilation system. The system is operated so that the air pressure within the facility can be maintained less than the air pressure outside the perimeter walls. The air system is balanced so that airflow within the facility is from areas with the least hazard potential to areas with the greatest hazard potential.

The air-handling system should provide an air supply consisting of 100 percent outdoor air on a year-round basis. The system should provide separate branch supply and exhaust air ducts to each space to permit proper air balance. The air ducting should be tightly constructed to ensure control of air balance. The supply and exhaust fans should be interlocked to prevent pressurization in the event of exhaust fan failure.

The general exhaust air is filtered by passage through high-efficiency particulate air (HEPA) filters before being discharged to the outdoors. The air filters should be located as near to the laboratory module as possible to minimize the length of potentially contaminated air ducts. The filter plenums should be designed to facilitate (i) testing of filters after installation, and (ii) in-place decontamination before filter removal and replacement.

Mechanical systems should be designed so that maintenance of building machinery, piping, and controls can be performed from outside the laboratory environment.

Liquid effluents from the P4 facility should be collected and decontaminated before disposal into the sanitary sewers. Effluents from laboratory sinks, cabinets, floors, and autoclaves should be sterilized by heat treatment. Liquid wastes from the shower room may be decontaminated with chemical disinfectants (see Section II,E). The wastes from toilets may be discharged directly into the sanitary sewers.

The figure on the following page shows the secondary barriers of the P4 facility.

Primary protection for the laboratory worker within the P4 facility is provided by the use of Class III Biological Safety Cabinets. The exhaust fans for the Class III cabinets are separate from the exhaust fans of the facility ventilation system.

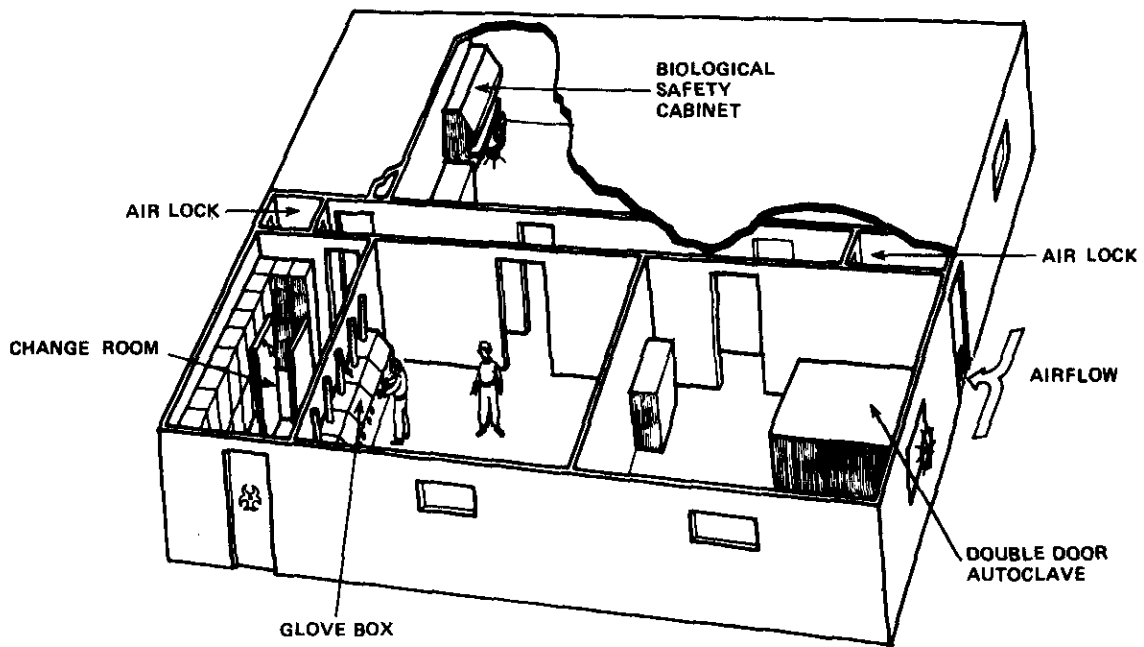
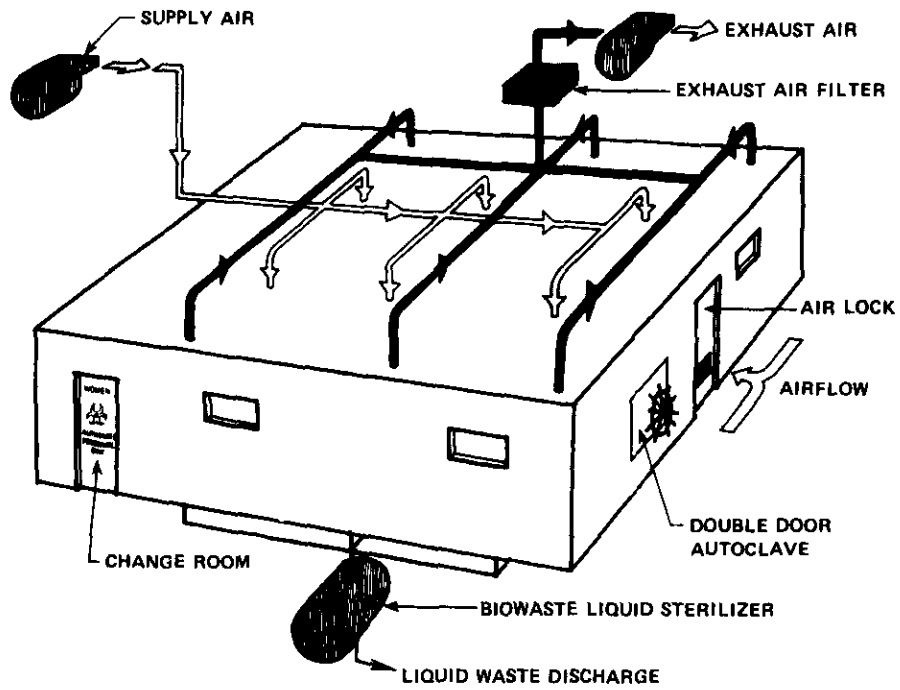

**SECONDARY BARRIERS IN REPRESENTATIVE P4 FACILITY**

Primary protection may also be provided by having the laboratory worker wear a one-piece positive pressure suit while working in a specially designed suit area within the P4 facility. The suit area is isolated from other areas of the P4 facility by an air lock fitted with airtight doors, a double-door autoclave, and a chemical disinfectant shower. The air pressure within the suit area is less than that in any adjacent area. The exhaust air from the suit area is separately filtered through two sets of HEPA filters installed in series, or filtered by a single HEPA filter, then incinerated before being discharged to the atmosphere. A duplicate filtration system and exhaust fan is provided. An emergency power source to operate the exhaust fans is also provided. The interior surfaces of the suit area have monolithic finishes, and all penetrations for utility services and air ducts through walls, floors and ceilings are sealed.



### C. Certification Procedures

Safe conduct of recombinant DNA research is dependent, in part, on the design and operation of the research facility. Facilities that support research at the P3 and P4 physical containment levels must provide certain facility "barrier" systems or safeguards that serve to protect persons and the environment outside of the laboratory setting from potential hazards associated with research. The appropriateness of a facility to support recombinant DNA research is, therefore, dependent on the performance of these facility safeguards.

This section describes the minimum certification requirements for P3 and P4 facilities. These requirements are summarized in the following table. It is also important that all mechanical systems and equipment of the facility are operating satisfactorily and that appropriate maintenance is provided to insure continuous satisfactory operation.

Adaptation or development of new procedures for certification are encouraged for situations where these procedures may not be applicable or best suited. A modified or new procedure would be acceptable provided it is capable of demonstrating that the criteria for certification are achieved.

## MINIMUM CERTIFICATION REQUIREMENTS FOR P3 AND P4 FACILITIES

Facility Barrier System	P3 Facility	P4 Facility	P4 suit room with Primary Barriers	P4 suit room without Primary Barriers
Access control	Comply conceptually with any arrangement in the figures on page 149	Contiguous change room/shower facility	Airtight air lock with chemical shower	Airtight air lock with chemical shower
Penetration seals	Integrity demonstrated by visual onsite inspection	Integrity demonstrated by visual onsite inspection	Integrity demonstrated by visual onsite inspection	Integrity demonstrated by field tests (see certification procedure 1)
Directional airflow	Performance demonstrated by field tests (see certification procedure 2)	Performance demonstrated by field tests (see certification procedure 2)	—	—
Negative air pressure	—	—	Negative with respect to all adjacent areas as demonstrated by field measurements (see certification procedure 3)	Negative with respect to all adjacent areas as demonstrated by field measurements (see certification procedure 3)
Exhaust air ducts (layout)	No cross connection with supply ducts as demonstrated by on-site inspection	No cross connection with supply ducts or exhaust ducts from non-P4 areas as demonstrated by on-site inspection	Isolated exhaust system as demonstrated by onsite inspection	Isolated exhaust system as demonstrated by onsite inspection
Exhaust air ducts (tightness)				
existing installation	—	Sufficiently tight construction to assure directional airflow	Sufficiently tight construction to assure negative air pressure	Integrity demonstrated by field tests (see certification procedure 4)
new construction	—	Integrity demonstrated by field tests (see certification procedure 5)	Integrity demonstrated by field tests (see certification procedure 5)	Integrity demonstrated by field tests (see certification procedure 4)
Steam and Ethylene Oxide Sterilizers	Performance demonstrated by field tests (see certification procedure 6)	Performance demonstrated by field tests (see certification procedure 6)	Performance demonstrated by field tests (see certification procedure 6)	Performance demonstrated by field tests (see certification procedure 6)
Exhaust air filter efficiency	—	Performance demonstrated by field tests (see certification procedure 7)	Performance demonstrated by field tests (see certification procedure 7)	Performance demonstrated by field tests (see certification procedure 7)
Biowaste treatment facility	—	Performance demonstrated by field tests (see certification procedure 8)	—	—

1. Certification of Leak Tightness of Penetration Seals For P4 Suit Rooms Without Primary Barriers

This test should be performed to verify the tightness of penetration seals of a P4 suit area when this area is to be used to contain hazardous microorganisms outside of Biological Safety Cabinets or other primary barriers. The purpose of this test is to demonstrate the integrity of all seals for penetrations of pipes, ducts, electrical conduits, etc., where they penetrate walls, floors and ceilings of the P4 suit area. (For P3 and P4 facilities, and P4 suit areas in which potentially hazardous agents are to be confined in primary barriers, it is sufficient to judge the integrity of penetration seals by visual inspection. Acceptance, in this case, would be based on the absence of visual openings around pipes, ducts, conduits, etc., where they pass through walls, floors and ceilings of the facility.)

a. Equipment Required

- (1) Industrial type halogen leak detector, General Electric Ferret, G. E. Catalog No. 50-420-810 HFJK or equal.
- (2) Calibrated leak standard, General Electric LS-20, Catalog No. 50-420 701AAAMI ( $0-10 \times 10^{-7}$  cc/sec) or equal.
- (3) Tank(s) of halide gas (dichlorodifluoromethane).
- (4) Respirator equipped with a cartridge for organic vapor removal to be worn by person generating gas on high pressure side.
- (5) Two-way communication system.

b. Test Procedure

- (1) Remove halogenated compounds from the test area.
- (2) Calibrate the leak detector according to the manufacturer's instructions. Adjust the leak standard to indicate a leak rate of  $1 \times 10^{-4}$  cc/sec.
- (3) Prior to testing, perform a background scan of the area to insure the atmosphere is free of halogenated compounds.

(4) Verify that the air pressure in the laboratory area to be tested is negative with respect to all adjacent areas.

(5) Form a "tent" using plastic sheeting around the penetration area on the high pressure side of the wall, floor or ceiling.

(6) Introduce into the "tent" sufficient halide gas (dichlorodifluoromethane) to produce a "cloud" of gas around the penetration.

(7) On the low pressure side of the penetration area, scan the entire seal with the probe of the halogen leak detector.

c. Test Criterion

No halogen leakage shall be detected when the halogen leak detector is set at a sensitivity of  $1 \times 10^{-4}$  cc/sec.

## 2. Certification of Directional Airflow

This test is conducted to verify that the movement of air is from spaces of lower contamination potential to spaces of higher contamination potential. For example, air should always move from access corridors into laboratory modules.

### a. Equipment Required

(1) Mine Safety Appliance Company, Inc., ventilation smoke tubes #5645 or equal.

(2) Space plans of test area.

### b. Procedure

(1) Indicate on floor space plans of facility test area the required direction of airflow across each door of the test area.

(2) Verify that the air-handling system supporting the facility is operating normally.

(3) Close all doors of the facility test area.

(4) Determine the direction of airflow across a doorway by opening the door about one inch and holding the smoke tube vertically in the door opening. Observe the direction of smoke movement. Test one door at a time.

(5) Verify that the actual direction of airflow is in accordance with the required direction of airflow as indicated on the space plans. Where this condition is not met, the air-handling system should be rebalanced and the test repeated until the required direction of airflow is achieved.

### c. Test Criterion

Movement of air is from spaces of lower contamination potential to spaces of higher contamination potential.

### 3. Certification of Negative Pressure Within P4 Suit Areas

This test is to verify that the air pressure within the P4 suit area is less than that in all spaces immediately adjacent to the suit area. Magnehelic gages are to be permanently installed so that the pressure differential between all adjacent spaces and the suit area can be continuously monitored.

#### a. Equipment Required

(1) Magnehelic gages with scale divisions calibrated to read in hundredths of an inch water gage. An appropriate number of gages are to be installed so that the pressure differential between all adjacent spaces and the suit room can be measured.

(2) Inclined manometer (0-0.5 inch water gage).

#### b. Test Procedure

(1) Verify that all gages have an accuracy of  $\pm 2\%$  for full-scale readings at 70°F. These gages may be tested by comparison with a liquid-filled inclined manometer.

(2) Balance the air-handling system of the P4 suit area and the P4 facility.

(3) Measure the air pressure differential as indicated on each magnehelic gage.

#### c. Test Criterion

The negative pressure within the P4 suit area is acceptable when it is below that of all spaces immediately adjacent to the suit area.

4. Certification of the Leak Tightness of Exhaust Air Ducts from the P4 Suit Area

The purpose of this test is to demonstrate that the exhaust air ducts from P4 suit areas in which work is conducted on the open bench are leak tight. This test is to be conducted for the general exhaust ducts that run from the suit area to and including the "clean" side of the HEPA filter plenums.

a. Equipment Required

- (1) Industrial-type halogen leak detector, General Electric Ferret, G. E. Catalog No. 50-420-810 HFJK or equal.
- (2) Calibrated leak standard, General Electric LS-20, Catalog No. 50-420 701 AAAMI ( $0-10 \times 10^{-7}$  cc/sec) or equal.
- (3) Tank(s) of halide gas (dichlorodifluoromethane).
- (4) Manometer, magnehelic gage or U-tube water column (graduated to read in inches water gage).
- (5) Plates to close off and seal all openings in the duct section to be tested.
- (6) A source of air pressure (i.e., portable or tank type vacuum cleaner; high pressure blower).

b. Test Procedure

- (1) Shut down exhaust fan and close off and seal openings in the duct section to be tested.
- (2) Attach a manometer or pressure gage to the duct section to be tested.
- (3) Provide access means to introduce halide gas to pressurize the duct with air.
- (4) Remove all halogenated compounds from the vicinity of the test area.
- (5) Calibrate the leak detector according to the manufacturer's instructions. Adjust the leak standard to indicate a leak rate of  $1 \times 10^{-4}$  cc/sec.

(6) Prior to testing, perform a background scan of the area to insure the atmosphere is free of halogenated compounds.

(7) After the space has been shown to be free of background interference, release into the duct section to be tested, one ounce of the halide gas for each 30 cubic feet of duct volume. This amount of halide gas will create a concentration of approximately 1% halide gas by volume. After the halide gas has been introduced into the duct, bring the total pressure to three inches water gage using air.

(8) Scan all joints, seams, flanges, etc., of the duct. The leak detector probe is held close to the surface to be tested (but not touching) and it should be moved at approximately one inch per second. Mark all points of leakage. Make repairs, retest for background, and then add halide gas and retest.

(9) Continue testing in this manner until the entire duct is leak tight.

c. Test Criterion

No halogen leakage shall be detected when the halogen leak detector is set at a sensitivity of  $1 \times 10^{-4}$  cc/sec.



5. Certification of Leak Tightness of General Exhaust Air Ducts  
(New Construction)

The purpose of this test is to demonstrate that newly constructed general exhaust air ducts of P4 facilities are sufficiently airtight. This is important to insure the effective control of air balance and to reduce the potential for escape of airborne contaminants (across duct seams, joints, flanges, etc.) in the event of fan failure. This test is to be conducted for the general exhaust air ducts that run from the individual areas of the P4 facility to and including the "clean" side of the HEPA filter plenum. This test does not apply to exhaust ducts from Class III cabinets. Contaminated exhaust ducts from Class III cabinets to the clean side of the second HEPA filter or incinerator shall meet the same leak tightness requirements specified for Class III cabinets (Section III, B, 6). The test given here was adopted from the "High Pressure Duct Construction Standards," Sheet Metal and Air Conditioning Contractors National Association, Inc., Third Edition, 1975.

a. Equipment Required

(1) A source of air pressure (i.e., portable or tank type vacuum cleaner; high pressure blowers).

(2) A flow-measuring device, usually an orifice assembly consisting of straightening vanes and an orifice plate mounted in a straight tube with properly located pressure taps. Each orifice assembly is accurately calibrated with its own calibration curve. Pressure and flow readings are usually taken with U-tube manometers.

(3) A typical test apparatus is shown in the figure that follows the next page.

b. Procedure

(1) With the air-handling system operating normally, determine the negative pressure at the "contaminated" side of the HEPA filter plenum.

(2) Shut down fan and close off and seal all openings in the duct section to be tested. Connect the test apparatus to the duct by means of a section of flexible duct.

(3) Start the air source with its control damper closed.

(4) Gradually open the inlet damper until the duct pressure reaches a positive pressure equivalent to 2 inches water gage plus the numerical value of the negative pressure as determined in step (1) (e.g., if the negative pressure measured at the "contaminated" side of the HEPA filter plenum were 4 inches water gage, then the test positive pressure should be 6 inches water gage). The test pressure is read on Manometer No. 1 shown in the following illustration. Note that the pressure is indicated by the difference in level between the two legs of the manometer and not by the distance from zero to the reading on one leg only.

(5) Survey all joints listening for audible leaks. Mark each leak and repair after shutting down test blower.

(6) After all audible leaks have been repaired, reestablish test pressure.

(7) Read the pressure differential across the orifice on Manometer No. 2. The leakage rate in cfm is read directly from the calibration curve for the test orifice plate.

#### c. Test Criterion

Total allowable leakage under conditions of the test should not exceed one percent of the total system design airflow rate. When partial sections of the duct system are tested, the summation of the leakage for all sections shall not exceed the total allowable leakage.

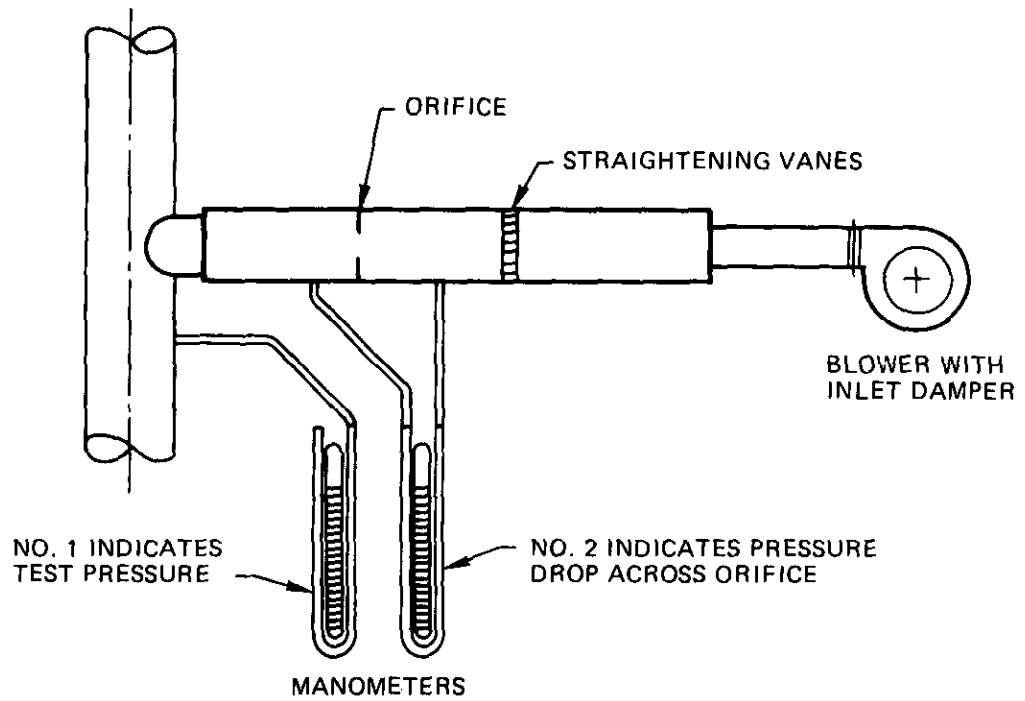

MANOMETERS USED FOR LEAK TIGHTNESS TESTING

Courtesy of SMACNA High Pressure  
Duct Standards - 3rd. Ed.

## 6. Certification of Steam and Ethylene Oxide Sterilizers

Steam sterilizers are important barrier systems used in research with potentially hazardous microorganisms. They are used as the principal devices for sterilizing contaminated wastes to insure safe disposal. Ethylene oxide sterilizers may also be used in certain applications where items to be sterilized may be adversely affected by steam sterilization conditions. Good safety management requires that the efficacy of these sterilization devices be verified before they are used for the sterilization of materials contaminated with potentially hazardous microorganisms. The tests described here are designed to demonstrate the performance of steam and ethylene oxide sterilizers.

### a. Equipment and Materials Required

(1) Spore strips containing both Bacillus subtilis var. niger and Bacillus stearothermophilus. (Amsco's Spordi<sup>R</sup> or equal)

Employ separate spore strips with an average certified population of 10,000 B. stearothermophilus and 1,000,000 B. subtilis spores, adjusted to the following resistance data.

<u>Test Organism</u>	<u>Sterilization Medium</u>	<u>Exposure Time &amp; Temperature (°F)</u>	
		<u>Survives</u>	<u>Killed</u>
<u>B. stearothermophilus</u>	Steam	250°, 5 min.	250°, 13 min.
<u>B. subtilis</u>	EtO	15 min.	1 hour, 45 min.

(2) Temperature indicator with remote probes.

(3) Hand towels, 16 x 24 inches.

(4) Stainless steel pan approximately 12" x 18" x 2" deep.

(5) Supporting laboratory equipment (incubator, refrigerator, culture media, miscellaneous glassware).

### b. Steam Sterilizer Test Procedure

(1) Fold in half three hand towels and stack them in the stainless steel pan. Place one test spore strip into the fold of the top and bottom towels. Do not remove the spore strips from their glassine envelopes.

(2) Place the temperature probe into the folds of the center towel with the lead extended over the lip of the pan. Place a second probe in the sterilizer drain. Position the pan in the rear center of the sterilizer away from the steam inlet. Pass the temperature leads out of the sterilizer chamber and connect to the recorder.

(3) Close the door, taking care not to cut the probe lead wires.

(4) Operate the sterilizer in accordance with the manufacturer's instructions. The cycle (time and temperature of exposure) shall be set as follows:

Set the minimum time that is required to kill the test spore strips located in the test pan. Use approximately the "kill" time and temperature established above once the temperature indicator located in the test pan reaches 250°F or 121°C.

(5) Record the temperature readings from the indicator (probe leads inside the sterilizer) at three-minute intervals. Simultaneously, record the chamber temperature, chamber pressure, and jacket pressure as shown by the sterilizer indicator.

(6) Upon completion of the cycle, rapidly exhaust the chamber and then remove the test spore strips from the sterilizer.

(7) Aseptically remove all test spore strips and two unheated control strips from their glassine envelopes with sterile forceps and place in previously prepared 12 x 150 mm tubes containing 10 ml of sterile Trypticase Soy Broth.

(8) Incubate one set of test and control tubes for seven days at 55°C for Bacillus stearothermophilus detection. Incubate the second set of test and control tubes for seven days at 37°C for Bacillus subtilis var. niger detection.

(9) All test organisms on each test strip must be killed (i.e., no growth may be visually present after incubation). The control strip must show positive results after incubation.

(10) In the event of test failure, corrective action (e.g., readjustment of steam sterilizer time/temperature) must be undertaken. The test must then be repeated to ensure that the adjustment was successful.

c. Ethylene Oxide Sterilizer Test Procedure

(1) Fold in half three hand towels and stack them in the stainless steel pan. Place one test spore strip into the fold of the top and bottom towels. Do not remove the spore strips from their glassine envelopes.

(2) Position the pan in the rear center of the sterilizer away from the gas inlet.

(3) Operate the sterilizer in accordance with the manufacturer's instructions.

(4) Upon completion of the gas cycle, rapidly exhaust the chamber and then remove the test spore strips from the sterilizer.

(5) Aseptically remove all test spore strips and two unexposed control strips from their glassine envelopes with sterile forceps and place in previously prepared 12 x 150 mm tubes containing 10 ml of sterile Trypticase Soy Broth.

(6) Incubate one set of test and control tubes for seven days at 55°C for Bacillus stearothermophilus detection. Incubate the second set of test and control tubes for seven days at 37°C for Bacillus subtilis var. niger detection.

(7) All test organisms on each test strip must be killed (i.e., no growth may be visually present after incubation). The control strip must show positive results after incubation.

(8) In the event of test failure, corrective action (readjustment of gas concentration and/or exposure time) must be undertaken. The test must then be repeated to ensure that the adjustment was successful.

d. Test Criterion

All spores on each test strip must be killed.

#### 7. Leak Testing of High-Efficiency Particulate Air (HEPA) Filters

The general exhaust air from P4 facilities is filtered by passage through high-efficiency particulate air (HEPA) filters before being discharged to the outdoors. The capability of these filters and their housings and mounting frames to prevent the escape of potential airborne contaminants must be demonstrated as part of the certification for P4 facilities. The acceptance criterion is that there be no detectable leaks when tested by the method described in Section III,B,7, entitled "Leak Testing of High-Efficiency Particulate Air Filters (HEPA)."

- a. Equipment Required - (Section III,B,7,a, page 142)
- b. Test Procedure - (Section III,B,7,b, page 142)
- c. Test Criterion - (Section III,B,7,c, page 144)

## 8. Certification of the P4 Facility Liquid Biowaste Treatment System

Two types of biowaste treatment systems are available to sterilize liquid effluent from the P4 facility. One system is designed and operated as a continuous flow heat exchange sterilization system. This system consists of coiled tubing that passes through a sealed heat exchange shell. Liquid effluent storage tanks are required to collect untreated liquid effluent and to insure continuous operation of the system over a fixed period of time. To conserve energy, an efficient heat exchange unit is necessary. This system is recommended when the effluent flow rate is in excess of 25 gpm. The second system is a pressure-rated effluent batch sterilization tank. The effluent in this type tank may be heated by injecting steam into a steam jacket or an internal steam coil, by immersed electrical resistance coils, or by oil- or gas-operated burners. Two full-sized batch tanks are required so that while one tank is being used to sterilize the effluent from the P4 facility the other is being used to collect effluent from the facility. Both systems must be designed and equipped with a sealed sampling system to facilitate certification testing.

This certification test is to be conducted to verify the sterilization efficacy of the P4 Biowaste Treatment System. Once this has been proven for the system, the operating temperature, pressure, and quantity or flow rates used for the successful test are to be established as the standard operating conditions for the system.

### a. Equipment and Materials Required

- (1) Stock concentrations of Bacillus subtilis var. niger spores.
- (2) Thermocouples and gages for insertion into the biowaste system to record temperature, pressure, quantity, and/or flow rates.
- (3) Equipment to take periodic samples from the sampling system (sterile needles and syringes, decontaminating chemical solutions, sterile transfer containers).
- (4) Other support laboratory equipment (culture media, pipettes, accessibility to an autoclave, incubator, etc.).



b. Test Procedure

(1) Determine and prepare the quantity and concentration of B. subtilis spore suspension required to test the biowaste treatment system. The final test concentration of the challenge liquid waste is to be approximately  $1 \times 10^5$  spores/ml.

(2) Sterilize or chemically disinfect the sampling system and verify that the system is free of viable contamination.

(3) Fill the biowaste treatment system to operating capacity with water.

(4) Add the spore suspension to the system in a manner to effect adequate mixing of the bacterial spores in the challenge liquid waste.

(5) Take control samples of both the initial stock spore suspension and of the challenge liquid effluent within the biowaste treatment system. Determine the concentration of each suspension by preparing serial dilutions of these samples. Plate in triplicate 0.1 or one ml of each diluent sample on Trypticase Soy Agar.

(6) Operate the biowaste treatment system through a normal cycle. Record operating temperatures, pressures, and quantities or flow rates.

(7) Aseptically collect a minimum of three - 100 ml samples of final-treated effluent. Prepare serial dilutions and plate in triplicate 0.1 or one ml samples on Trypticase Soy Agar. The remaining original sample and each diluted sample are to be filtered through a 0.2  $\mu$ m size membrane filter. Aseptically place the membrane filters on Trypticase Soy Agar. Incubate culture plates at 37° C for a total of 72 hours. Culture plates are to be examined at 24, 48, and 72 hours for growth.

(8) Three replicate tests are to be conducted.

c. Test Criterion

All replicate test samples from liquid effluent following the sterilization cycle are to have no viable growth.

## V. Packaging and Shipping of Recombinant DNA Materials

Federal regulations and carrier tariffs have been promulgated to ensure the safe transport of hazardous biological materials. The NIH Guidelines specify that all organisms containing recombinant DNA molecules will be packaged and shipped in containers that meet the requirements of these regulations and carrier tariffs.

### A. Instruction for the Packaging of Host and Vector Organisms Containing Recombinant DNA Molecules

#### 1. Volume less than 50 ml

Place the material in a securely closed, watertight container [primary container (test tube, vial, etc.)]. Place the primary container in a second, durable watertight container (secondary container). Several primary containers may be enclosed in a single secondary container if the total volume of all the primary containers so enclosed does not exceed 50 ml. Fill the space at the top, bottom, and sides between the primary and secondary containers with sufficient nonparticulate absorbent material to absorb the entire contents of the primary container(s) in case of breakage or leakage. Then enclose each set of primary and secondary containers in an outer shipping container constructed of corrugated fiberboard, cardboard, wood, or other material of equivalent strength.

If dry ice is used as a refrigerant, it must be placed outside the secondary container(s).

Descriptions of this packaging method are given in the following table.

**DESCRIPTION OF PACKAGES FOR MATERIAL IN VOLUMES LESS THAN 50 ml.**

Volume (ml)	Primary Container	Packing	Secondary Container	Packing	Outer Shipping <sup>d</sup> Container
15 max.	Sealed vial(s) or small glass test tube, screw cap* or stopper, taped	a	Metal can 1" diam. x 7" O.D. metal screw cap	None Required	Fiberbody; metal screw cap, top and bottom; 1½" diam. x 7 to 7½" O.D.
50 or less	One 20 x 150 mm test tube, taped* stopper or multiple small vials	a	Metal can 2½" diam. x 6½" high O.D. screw cap	None Required	Fiberbody; metal screw cap, top and bottom; 3¼" diam. x 7 to 7½" O.D.
50 or less	Plastic* screw cap* bottle or Pyrex glass with skirt rubber stopper	a	Metal can 2½" diam. x 6½" high O.D. screw cap	None Required	Fiberbody; metal screw cap, top and bottom; 3¼" diam. x 7 to 7½" O.D.
50 or less	Multiple watertight vials or * tubes, taped stoppers	a	One or more friction-seal tin cans <sup>b</sup> 306 x 400 or larger	c	Fiberboard box

\*The flexibility of the plastic bottle requires that a stopper or screw cap be secured in place by adhesive tape. The usual equivalent-size glass flat-sided prescription bottle is too fragile for use. For air transport, all stoppers, corks, and caps on primary containers must be secured in place with wire, tape, or other means, and all screw-capped containers of unfrozen liquid must be placed in 5 or 6 mil polyvinyl tubing heat-sealed at both ends to prevent atmospheric decompression that may result in leakage past the screw cap.

O.D. = outside dimensions.

a Nonparticulate absorbent material at top, bottom and sides that will completely absorb contents of the primary container(s).

b 610 x 708 and 804 x 908 are trade designations for outside dimensions of 6-10/16 inches diameter x 7-8/16" height, and 8-4/16" x 9-8/16" .

c None required, but with the 306 x 400 cans or larger cans use sufficient nonparticulate shock-absorbent material to prevent rattling.

d If materials are to be refrigerated, it is recommended that an overpack be used to contain the refrigerant and the secured (original) outer shipping container. A leak proof outer container must be used for water ice. If dry ice is used the outer container must permit release of carbon dioxide. Interior supports must be provided to hold the container(s) in the original position(s) after wet or dry ice has dissipated.

## 2. Volumes of 50 ml or Greater

Place the material in a securely closed, watertight container (primary container). Enclose this container in a second, durable watertight container (secondary container). Single primary containers are not to contain more than 500 ml of material. However, two or more primary containers whose combined volumes do not exceed 500 ml may be placed in a single secondary container. Fill the space at the top, bottom, and sides between the primary and secondary containers with sufficient non-particulate absorbent material to absorb the entire contents of the primary container(s) in case of breakage or leakage. Then enclose each set of primary and secondary containers in an outer shipping container constructed of corrugated fiberboard, cardboard, wood, or other material of equivalent strength. Also place a shock-absorbent material, in volume at least equal to that of the absorbent material, between the primary and secondary containers at the top, bottom, and sides, between the secondary container and the outer shipping container. (The maximum amount of materials that may be enclosed within a single outer shipping container should not exceed 4000 ml.)

If dry ice is used as a refrigerant, it must be placed outside the secondary container(s). If dry ice is used between the secondary container and the outer shipping container, the shock-absorbent material is to be placed so that the secondary container does not become loose inside the outer shipping container as the dry ice sublimates.

Descriptions of packages that comply with the regulations of the Department of Transportation (DOT) are given in the following table.

### B. Labeling of Packages Containing Host and Vector Organisms that Contain Recombinant DNA Molecules

Material data forms, letters, and other information identifying or describing the material should be placed around the outside of the secondary container. The label for Etiologic Agents/Biomedical Material must be affixed to the outer shipping container. This label is described in the Code of Federal Regulations, paragraph (c) (4) of 42 CFR 72.25.

**DESCRIPTION OF PACKAGES FOR MATERIAL IN VOLUMES OF 50 ml OR GREATER**

Volume (ml)	Primary Container	Packing	Secondary Container	Packing		Outer Shipping Container	
				With Refrigerant	Without Refrigerant	With Refrigerant	Without Refrigerant
51 to 100 ml	Plastic* or Pyrex glass screw cap* bottle, rubber or skirt rubber stopper, taped*	a	Consists of metal container & outer container specified in Table 1	Styrofoam box shock-absorbent insulation	c	Fiberboard box closely fitting the styrofoam box, taped shut	Corrugated fiberboard or cardboard box, taped shut
100 max.	One 100 ml plastic* screw cap* narrow neck bottle or Pyrex glass, taped*	a	No. 3 crimp seal tin can 404 x 700 or a 1-gallon friction-seal tin can, 610 x 708, top soldered or clipped at 4 points b	Styrofoam box shock-absorbent insulation	c	Fiberboard box closely fitting the styrofoam box, taped shut	V3C cardboard box PS3 type, 9-3/16" x 9-3/16" x 11 1/4" high O.D. taped shut with 3" type PS3 tape
200 max.	Two 100 ml plastic* screw cap* bottles or Pyrex glass, taped	a	No. 3 crimp seal tin can 404 x 700 or a 1-gallon friction-seal tin can, 610 x 708, top soldered or clipped at 4 points b	Styrofoam box shock-absorbent insulation	c	Fiberboard box closely fitting the styrofoam box, taped shut	V3C cardboard box PS3 type, 9-3/16" x 9-3/16" x 11 1/4" high O.D. taped shut with 3" type PS3 tape
250 max.	One 250 ml plastic* narrow mouth screw cap* bottle or Pyrex glass skirted rubber stopper, taped*	a	No. 3 crimp seal tin can 404 x 700 or a 1-gallon friction-seal tin can, 610 x 708, top soldered or clipped at 4 points b	Styrofoam box shock-absorbent insulation	c	Fiberboard box closely fitting the styrofoam box, taped shut	V3C cardboard box PS3 type, 9-3/16" x 9-3/16" x 11 1/4" high O.D. taped shut with 3" type PS3 tape
500 max.	Two 250 ml plastic* screw cap* bottles or Pyrex glass bottles, taped*	a	2-gallon friction-seal tin can, 804 x 908, top soldered or clipped at 4 points b	Styrofoam box shock-absorbent insulation	c	Fiberboard box closely fitting the styrofoam box, taped shut	V3C cardboard box 12 1/2" x 12 1/2" x 10-3/16" high O.D. taped shut with 3" wide PS3 tape
500 max.	500 ml Pyrex glass bottle, rubber-skirt stopper, taped, or 500 ml plastic* bottle, narrow or wide mouth, screw cap*, taped	a	No. 12 crimp seal tin can 603 x 810 2-gallon friction-seal tin can, 804 x 908, top soldered or clipped at 4 points b	Styrofoam box shock-absorbent insulation	c	Fiberboard box closely fitting the styrofoam box, taped shut	V3C cardboard box 12 1/2" x 12 1/2" x 10-3/16" high O.D. taped shut with 3" wide PS3 tape. For the No. 12 can a cardboard box is ok taped shut

\*The flexibility of the plastic bottle requires that a stopper or screw cap be secured in place by adhesive tape. The usual equivalent-size glass flat-sided prescription bottle is too fragile for use. For air transport, all stoppers, corks, and caps on primary containers must be secured in place with wire, tape, or other means, and all screw-capped containers of unfrozen liquid must be placed in 5 or 6 mil polyvinyl tubing heat-sealed at both ends to prevent atmospheric decompression that may result in leakage past the screw cap.

O.D. = outside dimensions.

a Nonparticulate absorbent material at top, bottom and sides that will completely absorb contents of the primary container(s).

b 610 x 708 and 804 x 908 are trade designations for outside dimensions of 6-10/16 inches diameter x 7-8/16" height, and 8-4/16" x 9-8/16".

c Shock absorbent material, in volume at least equal to that between the primary and secondary container(s), at the top, bottom, and sides between the secondary container and the outer shipping container. The shock absorbent material shall be so placed that the secondary container(s) does not become loose inside the outer shipping container as the water ice or dry ice is dissipated.

In addition, if the materials to be shipped contain any portion of a plant pest (plant pathogens), which is so defined by the Department of Agriculture (USDA), the outer shipping container must have affixed to it the shipping label furnished by the USDA as part of the General, Courtesy, or Special Permits required for research with and shipment of such agents.

### C. Additional Shipping Requirements and Limitations for Host and Vector Organisms that Contain Recombinant DNA Molecules

#### 1. Domestic Transportation

##### a. Quantities less than 50 ml

The Air Transport Association's (ATA's) Restricted Articles Tariff 6-D, which specifies transportation requirements for hazardous materials shipped by air, was amended June 25, 1977. One of the provisions of this amended tariff, effective September 1, 1977, is that a large Shipper's Certificate must be used on domestic as well as international air shipments of etiologic agents and other hazardous materials.

This new requirement has prompted a review of applicable regulations and tariffs for alternatives to the use of this large Shipper's Certificate on small (less than 50 ml) shipments of etiologic agents sent by mail and airmail. The following statement has been reviewed with the U. S. Department of Transportation, the U. S. Postal Service, and the ATA, and it is consistent with the requirements of each of these agencies. In place of the large certificate, this statement should be used on all domestic shipments of organisms containing recombinant DNA molecules less than 50 ml in volume.

**NOTICE TO CARRIER**

This package contains LESS THAN 50 ml OF AN ETIOLOGIC AGENT, N.O.S., is packaged and labeled in accordance with the U.S. Public Health Service Interstate Quarantine Regulations (42 CFR, Section 72.25 (c) (1) and (4)), and MEETS ALL REQUIREMENTS FOR SHIPMENT BY MAIL AND ON PASSENGER AIRCRAFT.

This shipment is EXEMPTED FROM ATA RESTRICTED ARTICLES TARIFF 6-D (see General Requirements 386 (d) (1)) and from DOT HAZARDOUS MATERIALS REGULATIONS (see 49 CFR, Section 173.386 (d) (3)). SHIPPER'S CERTIFICATES, SHIPPING PAPERS, AND OTHER DOCUMENTATION OR LABELING ARE NOT REQUIRED.

\_\_\_\_\_  
Date

\_\_\_\_\_  
Signature of Shipper

\_\_\_\_\_  
Address  
\_\_\_\_\_

b. Quantities equal to or greater than 50 ml

Shipments of materials exceeding 50 ml in volume are restricted, by DOT regulations, to transport by cargo-only aircraft. When the volume of a single primary container exceeds the 50 ml limitation, this restriction must be indicated on a Shipper's Certificate. An appropriate certificate is shown on the following page.

When dry ice is used as a refrigerant, an ORA, Group A, dry ice label should be affixed to the outer shipping container. The amount of dry ice used and the date packed should be designated on the label.

**SHIPPER'S CERTIFICATION FOR RESTRICTED ARTICLES**  
(excluding radioactive materials)

*Two completed and signed copies of this certification shall be handed to the carrier. (Use block letters.)*

**WARNING:** Failure to comply in all respects with the applicable regulations of the Department of Transportation, 49-CFR, CAB 82 and, for international shipments, the IATA Restricted Articles Regulations may be a breach of the applicable law, subject to legal penalties. This certification shall in no circumstance be signed by an IATA Cargo Agent or a consolidator for international shipments.

This shipment is within the limitations prescribed for: *(mark one)*

passenger aircraft       cargo-only aircraft

Number of Packages	Article Number (int'l only See Section (V IATA RAR))	Proper Shipping Name of Articles as shown in Title 49 CFR, CAB 82 Tariff 6-D and (for int'l shipments) the IATA Restricted Articles Regulations. Specify each article separately. Technical name must follow in parenthesis, the proper shipping name for N.O.S. items.	Class	IATA Packing Note No. Applied (int'l only)	Net Quantity per Package	Flash Point (Closed cup) For Flammable Liquids	
						°C	°F

Special Handling Information:

*I hereby certify that the contents of this consignment are fully and accurately described above by Proper Shipping Name and are classified, packed, marked, labelled and in proper condition for carriage by air according to applicable national governmental regulations, and for International Shipments the current IATA Restricted Articles Regulations.*

Name and full address of Shipper

Name and title of person signing Certification

Date

Signature of the Shipper (see WARNING above)

Air Waybill No.\*

Airport of Departure\*

Airport of Destination\*

\*This box is optional for completion by issuing carrier.

Form 776



## 2. International Transportation

In addition to the packaging and labeling requirements of the regulations previously cited, international shipments of these materials must have one or more of the following documents—depending on the country of destination:

- Parcel Post Customs Declaration (PS 2966) tag.
- Parcel Post Customs Declaration (PS 2966-A) label.
- International Parcel Post—Instructions Given by Sender (POD 2922) label.
- Dispatch Note (POD 2972) tag.
- Shipper's Certificate specified in the current International Air Transport Association Tariff.

Individual country requirements are listed in "International Postage Rates and Fees" (USPO Publication 51).

### D. Packaging of Recombinant DNA Molecules

Recombinant DNA molecules shall be packaged to withstand leakage of contents, shocks, pressure changes, and other conditions incident to ordinary handling in transportation.

TO BE REVISED  
ROLES AND RESPONSIBILITIES

Section VI - A. pages 181 - 190

## VI. Roles and Responsibilities

### A. The Institutional Biosafety Committee

Research involving biological agents capable of causing disease or illness in man has been conducted for many decades. The protection of laboratory workers and the general environment from harm has been largely left up to the scientists directly involved in such research. This has apparently worked well, since there have been no major incidents of spread of disease outside of the laboratory and the number of laboratory-acquired illnesses have been relatively few. However, with the greatly intensified research now going on with known hazardous and potentially hazardous biological agents, it is prudent to provide some level of institutional oversight for such research activities. The "NIH Guidelines for Recombinant DNA Research" require that such oversight be provided by an Institutional Biosafety Committee (IBC) that serves the entire institution for research involving the application of recombinant DNA techniques. The committee is to act on behalf of the institution.

#### 1. Functions

The IBC should have three principal functions:

- Advise the institution on development and implementation of policies for the safe conduct of research involving recombinant DNA molecules.
- Review and oversee all recombinant DNA projects.
- Advise the institution and NIH whether proposals for research involving recombinant DNA molecules comply with "NIH Guidelines for Recombinant DNA Research" and institutional policies.

The "NIH Guidelines for Recombinant DNA Research" outline a number of duties and responsibilities of the IBC. These are summarized in the following table, which is arranged in a manner to give emphasis to the interrelationships among the institution, the principal investigator, the IBC, and the NIH in carrying out duties and responsibilities pertaining to the development and implementation of the "NIH Guidelines for Recombinant DNA Research."

## 2. Organization and Membership

Because of the different administrative schemes used by institutions engaged in recombinant DNA research, it is impossible to make specific suggestions as to the best method of establishing the IBC. An important basic principle to follow, however, is that the IBC should be established by the highest administrator in the institution. This establishes the institution-wide interests of the committee; involves top administration in the deliberations of the committee; and assures close communication between the committee and institutional officers.

The size of the committee will be somewhat dependent on the size and complexity of the institution; but, in general, committees of 9 to 15 members should be able to function quite satisfactorily. No committee should have less than five members. There should be provision for rotation of membership. This can be done by limiting the tenure of membership to three, four, or five years. Less than three years may be too short a time to develop the full effectiveness of the members and more than five years would seem to place too much of a burden on the members.

The qualifications of the individuals to serve on the IBC need careful consideration. The membership should include individuals from a diversity of scientific disciplines relevant to recombinant DNA technology. The fields could include microbiology, virology, molecular biology, epidemiology, and ecology. The membership should also include individuals who are knowledgeable about laboratory safety and engineering principles.

**TABULATION OF DUTIES AND RESPONSIBILITIES  
PERTAINING TO THE DEVELOPMENT AND IMPLEMENTATION  
OF NIH GUIDELINES FOR RECOMBINANT DNA RESEARCH**

DUTIES	RESPONSIBILITIES	
	Institution	National Institutes of Health
	IAd : Institutional Administration BSO: Biological Safety Officer IBC : Institutional Biosafety Committee PI : Principal Investigator	OD : Office of the Director, NIH ORDA: Office of Recombinant DNA Activities, NIGMS, NIH C : Other NIH Components RAC : Recombinant DNA Molecule Program Advisory Committee
<b>A. Developing NIH Guidelines and Policy</b>		
1. Prepare Guidelines and establish policy. Specify permissible, exempt and prohibited experiments.	PI : Recommend to ORDA or OD IBC : Recommend to ORDA or OD	ORDA: Support RAC RAC : Recommend to OD OD : Take action after appropriate notice and opportunity for public comment
2. Revise and amend Guidelines.	PI : Recommend to ORDA IBC : Recommend to ORDA	RAC : Recommend to OD ORDA: Recommend to OD OD : Take action after appropriate notice and opportunity for public comment
3. Promulgate and amend a list of classes of experiments to be exempt from Guidelines.	PI : Recommend to ORDA IBC : Recommend to ORDA	RAC : Recommend to OD ORDA: Recommend to OD OD : Take action after appropriate notice and opportunity for public comment
4. Designate classification of agents (on basis of hazard) for purposes of Guidelines.		RAC : Recommend to OD OD : Take action
5. Certify and de-certify host-vector systems. Maintain public listing.	PI : Submit information to ORDA	RAC : Advise OD ORDA: Advise OD OD : Take action after appropriate notice and opportunity for public comment ORDA: Administer
6. Permit exceptions to prohibitions.	PI : Notify IBC and request action of ORDA	RAC : Advise OD ORDA: Advise OD OD : Take action after appropriate notice and opportunity for public comment
7. Interpret Guidelines.	PI : Request action of ORDA IBC : Request action of ORDA	RAC : Advise OD Advise ORDA ORDA: Take action or recommend to OD OD : Take action
8. Publish <u>Recombinant DNA Technical Bulletin</u> .	PI : Provide information to ORDA IBC : Provide information to ORDA	ORDA: Take action
9. Ensure limitation of disclosure of confidential or proprietary information.	PI : Comply IBC : Comply IAd : Comply	NIH : Comply
10. Submit application for patent if information is regarded as proprietary.	PI : Initiate action IAd : Review and take action if desired	NIH : Respect proprietary information

<b>B. Establishing an Institutional Recombinant DNA Research Program</b>		
1. Establish an Institutional Biosafety Committee. Select and report names and qualifications to ORDA. Update information annually.	IAd : Take action	ORDA: Review and advise IAd
2. Appoint a Biological Safety Officer for projects at the P3 and P4 containment levels.	IAd : Take action	ORDA: Advise
3. Establish Institutional policies and practices to be followed in conforming with NIH Guidelines.	IBC : Recommend to IAd IAd : Take action	ORDA: Advise
4. Keep minutes of IBC meetings.	IBC : Take action	
5. Submit proposals to conduct recombinant DNA research to IBC.	PI : Take action	
6. Make independent determination of the required levels of physical and biological containment in accordance with NIH Guidelines.	PI : Take action IBC : Take action	ORDA: Take action
7. Select appropriate microbiological practices and laboratory techniques to be used in recombinant DNA research.	PI : Take action BSO: Advise re: P3 and P4	ORDA: Advise
8. For each recombinant DNA research project proposed by a PI, determine that facilities, procedures, and practices and the training and expertise of personnel are in compliance with NIH Guidelines.	BSO: Advise re: P3 and P4 IBC : Take action	ORDA: Take action C : Certify P4 facilities
9. Review each project and establish, if necessary, a medical surveillance program.	IBC : Recommend to IAd IAd : Take action	ORDA: Advise
10. Establish emergency plans.	PI : Recommend BSO: Recommend re: P3 and P4 IBC : Take action	ORDA: Advise
11. Execute an MUA (or submit equivalent information in case of non-NIH supported project to accomplish registration) and submit to NIH after approval by IBC. Each application to the NIH for a project that involves experiments subject to the NIH Guidelines must be accompanied by an MUA. For ongoing projects that will be introducing new recombinant DNA experiments, an MUA should be submitted to NIH within 30 days of approval by the IBC.	PI : Initiate BSO: Advise re: P3 and P4 IBC : Review and approve IAd : Take action	ORDA: Take action C : Transmit MUA to ORDA for review and approval

<b>C. Conducting the Research Program</b>		
1. Initiate no recombinant DNA research until it has been approved by the IBC.	PI : Take action	
2. Comply fully with Guidelines in carrying out research.	PI : Take action	ORDA: Advise
3. Adhere to IBC-approved emergency plans.	PI : Take action BSO: Advise re: P3 and P4	
4. Comply with shipping requirements for recombinant DNA molecules.	PI : Take action BSO: Advise re: P3 and P4	ORDA: Advise
5. Inform laboratory staff of approved safety protocols that describe the potential biohazards and precautions to be taken.	PI : Take action BSO: Advise re: P3 and P4	
6. Instruct and train staff in the practices and techniques required to ensure safety, and in the procedures for dealing with accidents.	PI : Take action BSO: Advise re: P3 and P4	ORDA: Advise
7. Inform staff of the reasons and provisions for any advised or requested medical practices, vaccinations, or serum collection.	PI : Take action	
8. Execute a revised MUA for projects involving substantial changes in protocol and submit to NIH within 30 days of approval by IBC.	PI : Initiate BSO: Advise re: P3 and P4 IBC: Review and approve IAd: Take action	ORDA: Take action; notify IAd when IBC-approved MUA does not conform to NIH Guidelines
9. Make changes to IBC-approved MUA to conform to ORDA review requirements.	PI : Take action IAd: Inform PI	ORDA: Advise
10. Request reductions in containment levels for purified DNA and characterized clones.	PI : Initiate IBC: Take action except for the following cases that are to be referred to ORDA (i) those involving primate DNA, (ii) requests for more than a single-step reduction, and (iii) requests for lowering containment levels below P1 and HV1. Notify ORDA of action or submit request to ORDA for action.	RAC : Advise ORDA ORDA: Take action

D. Supervising and Appraising of Safe Conduct of Research		
1. Supervise safe conduct of research.	PI : Take action	
2. Correct work errors and conditions that may result in the release of recombinant DNA materials.	PI : Take action	
3. Report promptly to the IBC and ORDA any problems or violations of the Guidelines.	PI : Take action IBC : Take action	ORDA: Review and recommend to OD OD : Take action
4. Investigate and report in writing to the IBC, ORDA, and the BSO (where applicable) any significant problems pertaining to operation and implementation of biological and physical containment safety practices and procedures.	PI : Take action BSO: Review and Advise re: P3 and P4 IBC : Review and take action	ORDA: Review, take action or recommend to OD OD : Take action as required
5. Provide advice on laboratory security.	BSO: Take action re: P3 and P4	ORDA: Advise

E. Monitoring of Safe Conduct of Research		
1. Ensure compliance of recombinant DNA projects with the procedures and standards of the NIH Guidelines.	IAd : Take action	ORDA: Advise
2. Review periodically recombinant DNA research being conducted at the institution.	IBC : Take action	
3. Ensure, through periodic inspection, that laboratory safety standards are rigorously followed (P3 and P4 containment levels).	BSO: Take action re: P3 and P4	C : Make on-site inspection at P4 facilities
4. Investigate and report in writing to ORDA and the IBC any serious or extended illness of a worker; any incident causing serious exposure to personnel or danger of environmental contamination; and any accident that involves inoculation of recombinant DNA material through the skin, by ingestion, or probable inhalation.	PI : Take action IBC : Review and take action	ORDA: Review, take action or recommend to OD OD : Take action as required
5. Ensure integrity of physical containment.	PI : Take action	
6. Ensure integrity of biological containment (e.g., genotypic and phenotypic characteristics, purity, etc.)	PI : Take action	
7. Oversee implementation of the NIH Guidelines.	IBC : Take action IAd : Take action	OD : Take action



Appointment of a nondoctoral person from a laboratory technical staff can provide a useful perspective of the working laboratory setting.

In addition to possessing the professional competence necessary to assess and review specific activities and facilities, the committee should possess, or have available to it, the competence to determine the acceptability of its findings in terms of applicable laws, regulations, standards of practices, community attitudes, and health and environmental considerations.

Individually, the members should be recognized by their colleagues as capable scientists and persons of good judgment. The members should each have a personal commitment to laboratory safety in general and biosafety in particular.

Any institution that has need for an IBC must recognize that there may be legitimate concern in the adjacent community about whether adequate safeguards are being taken at the institution to protect the general environment and community from potentially hazardous materials. How this concern might best be dealt with will vary from one community to another, but the institution should not ignore this concern. One suggestion is that community individuals with either statutory or political responsibility for the health and well-being of the residents of the community be invited to attend the meetings of the IBC and to participate in the deliberations of the committee when matters of concern to the public are under consideration. The minutes of the committee meetings could be shared with these individuals upon request. Another suggestion would be to appoint such an individual to serve as a member of the committee.

### 3. General Recommendations

An independent assessment of the physical and biological containment levels for each recombinant DNA project and the analysis of requests for single step reductions in containment levels for experiments with purified DNA and characterized clones require considerable scientific

expertise, as well as scientific judgment. Not all IBCs will have among its members sufficient background and experience to deal thoroughly with the technical aspects of all project proposals that come to its attention. Advice and consultation from institutional scientists who are not members of the IBC may be desirable and necessary. It is suggested, therefore, that the IBC identify institutional scientists who could serve as consultants to the committee. The use of such consultants in supporting the work of the committee is to be encouraged.

Many institutions have established environmental health and safety programs that deal with the broad area of laboratory safety. These programs are likely to have resources and capabilities that could be used to support the work of the IBC. For example, such programs may be well equipped to perform surveillance and monitoring of safety practices; review the integrity of safety equipment and facilities; investigate problems pertaining to operations and implementation of physical containment safeguards; investigate accidents causing serious exposure to personnel or danger of environmental contamination; assist principal investigators in the selection of appropriate safety practices and equipment and in the preparation of MUAs; and develop emergency procedures. These programs could also provide staff support to the IBC. It is suggested, therefore, that the IBC utilize the resources and capabilities of environmental health and safety programs, where appropriate, in the support of the work of the committee. This arrangement could be most beneficial in areas dealing with operational responsibilities of the committee such as those listed above.

The work of the committee should be conducted in a deliberate but timely manner. The process by which the committee functions should be well defined and known by all institutional scientists who may wish to use recombinant DNA techniques in their research. This suggests that the procedures to be used by the committee and the logistics for maintaining communication with the principal investigator and other interested persons

should be documented. This will facilitate cooperation and will minimize difficulties in conducting the work of the committee.

The following steps and procedures are offered for an IBC for reviewing and approving MUAs:

- The principal investigator should submit the proposed MUA to the executive secretary or the chairman of the IBC. It would be preferable to submit the document to the executive secretary, who would assign an identification number for administrative control during the review process and for future reference. The executive secretary would then initiate the review process.

- The MUA should then be transmitted to committee members. The members who receive the MUA may vary, depending on the workload, the proposed level of physical containment, and the committee review process. All committee members, however, should receive copies of any MUA for which the principal investigator has determined that a P3 or P4 level of physical containment would be required.

- It may be advisable to establish a scientific subcommittee that would be responsible for conducting an independent assessment of the physical and biological containment levels appropriate for a submitted MUA. This subcommittee should have sufficient flexibility to seek advice from other scientists, as required. After it has completed its assessment, the subcommittee should also be encouraged to discuss with the principal investigator any differences it has with respect to the initial assessment performed by the principal investigator. This may facilitate an early modification to the MUA, if required, prior to formal committee action.

- The subcommittee should submit its recommendations to the IBC within one month after receipt of the MUA, or sooner, if possible.

- Following IBC approval of the assessment conducted by the subcommittee, the IBC should determine that the required safeguards and expertise of the project staff for the assessed level of physical containment are available. Such a determination may require a visit to the laboratory in which the project is to be conducted. Visits for projects requiring P3 or P4 levels of physical containment should be coordinated by the biological safety officer. The professional staff of the institution's environmental health and safety program may be helpful in performing this task for the committee. Once this review has been completed, the committee would be in a position to make a final decision on the MUA.

- The final decision on the MUA should be transmitted, in writing, to the principal investigator. An approved copy of the MUA would serve this purpose. The committee should also initiate the submittal process for notifying NIH of the IBC approval action.

- The IBC should develop a mechanism for reviewing periodically all projects having approved MUAs. This should be done to determine if new data or revised guidelines for assessing potential hazards warrant the revision of the MUA. Also, the IBC should be advised as to whether the project has been completed, temporarily stopped, or terminated for any reason.

## B. The Biological Safety Officer

The "NIH Guidelines for Recombinant DNA Research" require that institutions engaged in recombinant DNA research at the P3 or P4 physical containment levels appoint a person who will serve as a biological safety officer. The following duties will be among those to be performed by the biological safety officer:

- Provide technical advice to the principal investigator and IBC on research safety procedures.
- Provide advice on laboratory security.
- Develop emergency plans for dealing with accidental spills and personnel contamination; and investigate recombinant DNA research laboratory accidents.
- Ensure through periodic inspections that laboratory standards are rigorously followed.
- Serve as a member of the IBC.

The principal function of the biological safety officer should be to advise the principal investigator, the IBC and the laboratory worker concerning the most appropriate safety practice that will assure the safe conduct of recombinant DNA research.

Depending on the nature and extent of the institution's recombinant DNA programs, the biological safety officer may be a full-time position, or the duties may be assigned to an individual who has other responsibilities. Where the institution has a comprehensive environmental health and safety program that includes expertise in biological safety, it would be useful to select the individual from the program's professional staff. This would ensure effective collaboration with other safety professionals and would allow all elements of a laboratory safety program to be carried out in a unified manner. Where this expertise does not exist, the appointed individual should interact closely with the basic safety group of the institution. If the position is to be full-time, consideration should be given to assigning this position to the basic health and safety program, rather than creating a separate program for biosafety in a different administrative setting.

The qualifications of the individual need careful consideration. Familiarity with the laboratory setting and the basic scientific techniques and manipulations common to biomedical research is important. Ideally, the person should have experience in working within a biomedical research setting. A technical background in basic microbiology and knowledge of biological safety techniques and practices, containment equipment, and engineering principles pertaining to the design and operation of facility safeguards are also important. The individual should be able to communicate effectively with technical, administrative, and support personnel.

Additional duties and responsibilities may be assigned to the biological safety officer. These will depend on the magnitude and complexity of the institution's recombinant DNA program, whether the position is full- or part-time, the relationship of the position to the institution's environmental health and safety program, and the qualifications of the individual. The following are examples of additional duties and responsibilities:

- Provide special laboratory safety training.
- Serve as a liaison with NIH and other research organizations on matters pertaining to laboratory safety.
- Conduct or supervise all testing programs designed to demonstrate the integrity of containment equipment and facility safeguards.
- Supervise emergency decontamination measures.
- Maintain a safety library of reference publications and training materials.
- Provide guidance and assistance concerning the packaging and shipping of recombinant DNA materials.

The full extent of these activities, if they were required, could not be carried out by a single person. These activities may be distributed, however, among the staff of the institution's environmental health and safety program. In such a case, the biological safety officer should be responsible for the management, supervision or coordination of these activities.

At the present time few individuals possess the experience and expertise to function independently as biological safety officers. Training, discussion of safety matters with other safety professionals, and on-the-job experience will help alleviate these shortcomings. Also, NIH is initiating a comprehensive training program on the practices and procedures for the control of biohazards in the research laboratory. The primary objective of this training effort will be to give detailed instruction on the duties of the biological safety officer.

### C. Emergency Procedures

Safety is an intrinsic part of each laboratory operation; work is planned so that exposure to potentially hazardous agents will not occur. In spite of this, accidents that create hazards do occur. These may involve spills of potentially hazardous agents in the open laboratory. Also, failure of important equipment and facility safeguards may place the laboratory worker at a high risk of accidental exposure. Likelihood of severe injury or infection can be reduced if plans for emergencies are established and are well known to all who need to know. For this reason, the "NIH Guidelines for Recombinant DNA Research" require the preparation of emergency plans for laboratories involved in this research.

It is not possible to recommend a single plan of action that would be applicable in all situations. The following basic principles, however, may be useful in developing specific procedures for dealing with accidental spills of potentially hazardous materials in the open laboratory.

- Get everyone out of the affected area.
- Do not reenter until the extent of the hazard is determined.
- Determine the necessity for treating persons exposed to the potentially hazardous materials.
- Decontaminate the affected area (see Section II,E,6).

For emergencies involving the failure of equipment or facility safeguards, the most important action should be to stop work with potentially hazardous materials and to safely contain these materials until corrective action has been taken.

An important principle in any emergency situation is that attention to the immediate personal danger overrides maintenance of containment. Potentially hazardous materials should be safely contained insofar as this is compatible with this principle. In cases of serious injury or sudden illness, the principal investigator should determine whether to override containment procedures.

Emergency plans for dealing with fire, explosion, and natural disaster are also important. Most institutions have plans developed for such situations, and extensive literature is available on this subject. The



following references are examples of such literature:

Manufacturing Chemists Association. 1972. Guide for safety in the chemical laboratory. Van Nostrand Reinhold Company, New York, NY.

McKinnon, G.P., and K. Tower, eds. 1976. Fire protection handbook. National Fire Protection Association, Boston, MA.

Morse, G.P., and R.F. Morse. 1974. Protecting the health care facility. The Williams and Wilkins Company, Baltimore, MD.

Steere, N.V., ed. 1971. Handbook of laboratory safety. The Chemical Rubber Company, Cleveland, OH.

Because all emergencies cannot be anticipated in advance, the National Institutes of Health and the Center for Disease Control are available to provide consultation and direct assistance, if necessary, to assist institutions in the management of specific emergency situations. Assistance can be obtained by contacting one of the following offices:

- Office of Research Safety  
National Cancer Institute  
National Institutes of Health  
(301) 496-1862
- Environmental Safety Branch  
Division of Research Services  
National Institutes of Health  
(301) 496-6034
- Office of Biosafety  
Center for Disease Control  
(404) 633-3311, Ext. 3883

#### D. Medical Surveillance

The "NIH Guidelines for Recombinant DNA Research" state that it is the responsibility of the Institution to "determine, in connection with each project, the necessity for medical surveillance of recombinant DNA research personnel before, during, and after their involvement in this research." The Guidelines further require the principal investigator to investigate and report "in writing to ORDA and the IBC any serious or extended illnesses of a worker or any accident that results in (i) inoculation of recombinant DNA materials through cutaneous penetration, (ii) ingestion of recombinant DNA materials, (iii) probable inhalation of recombinant DNA materials following gross aerosolization, or (iv) any incident causing serious exposure to personnel or danger of environmental contamination." These activities constitute the minimum requirements for a medical surveillance program for recombinant DNA research. The Guidelines also recommend that the medical surveillance program provide for collection and maintenance of serum samples and for the immunization of all workers who may work with known pathogens for which an effective vaccine is available. This section provides further guidance to institutions on activities that may be considered for inclusion in a medical surveillance program.

The extent of any medical surveillance program will vary greatly, depending upon the nature and size of the research project and the available medical facilities. For example, a comprehensive medical surveillance program including preassignment and periodic physical and other medical examinations may not be appropriate for laboratory workers involved in research requiring P1 and P2 levels of physical containment, whereas such a program may be advisable for workers engaged in certain research projects requiring P3 physical containment and would be recommended for workers engaged in research requiring P4 physical containment.

The objective of this review is to provide pertinent information and call attention to various functions related to medical surveillance that are recommended for consideration, insofar as they are applicable

to recombinant DNA research. These recommendations are intended to supplement normal pre-employment medical examinations that determine suitability of a prospective employee to a particular job situation.

## 1. Serum Collection Program

The collection and maintenance of serum specimens from laboratory workers engaged in research with potentially hazardous organisms will provide the potential for monitoring serological changes that may result from the employee's work experience. Serological conversion warns that accidents, procedures, or equipment have caused significant exposure of personnel to research material. A report of seroconversion is a clear signal calling for examination, identification, and revision of the laboratory procedures that have exposed the laboratory worker.

In order to establish a meaningful serum collection program, sera should be obtained from all personnel who may be potentially exposed to potentially hazardous organisms. This includes personnel handling potentially hazardous organisms as well as personnel assigned to areas where these materials are handled.

The principal investigator should arrange with the institution's medical service to establish a schedule to obtain serum specimens from each laboratory worker prior to the time that work with potentially hazardous organisms is initiated, at yearly intervals as a minimum frequency thereafter, and prior to termination of employment. In addition, serum specimens should be obtained immediately following an overt exposure and at an appropriate time after such an exposure. When agents which are known to be capable of producing a serological response are used in the research, it is advisable to prepare two samples each time serum is collected. One sample should be evaluated for antibodies and the other stored in a freezer for future reference.

## 2. Immunizations

Immunization is generally recommended for laboratory workers who will be engaged in research with infectious organisms for which an effective vaccine is available. At some institutions, prior immunization may be required for certain positions as a condition of employment. Where immunizations are required, evidence of antibody response should be demonstrated, whenever possible, before an employee begins to work with infectious organisms. Detailed information on vaccines and general recommendations for the immunization of laboratory workers can be found in "Lab Safety at the Center for Disease Control" U. S. Department of Health, Education, and Welfare, Public Health Service, HEW Publication No. CDC 77-8118.

### 3. Reporting and Investigating of Accidents and Illnesses

If an organism containing recombinant DNA molecules were to acquire the capacity to infect and cause disease in man, the first evidence of this potential may be demonstrated by a laboratory-acquired infection. For this reason it is important to investigate any serious, unusual, or extended illness of a laboratory worker engaged in recombinant DNA research or any accident that involves inoculation of organisms containing recombinant DNA molecules through the skin, by ingestion, or probable inhalation. A finding that infection is associated with recombinant DNA research will provide sufficient warning for evaluation of hazards and initiation of additional precautions to protect the general public, if such protection is necessary.

Prompt reporting of accidents involving overt exposures is essential (See Section VI, C, "Emergency Procedures"). The laboratory worker involved with such an occurrence should notify the principal investigator (or another person in authority in absence of the principal investigator) immediately. The principal investigator should determine the immediate action to be taken. This may include requesting the support of the medical service to help identify the possibility of infection and disease. A thorough investigation by the medical service would include the collection and analysis of appropriate clinical specimens. For example, if self-inoculation, cuts or abrasions involving a potentially hazardous organism occurred, it would be advisable to collect serum samples immediately after the incident and at an appropriate time following the incident for the purpose of demonstrating, if possible, seroconversion. After a massive aerosol exposure, it may be advisable to obtain nasal and skin cultures to confirm the exposure. Throat washings may be of value in confirming exposure following accidental ingestion. In the event that a laboratory worker develops diarrhea or other gastrointestinal symptoms following an overt exposure, it may be advisable to obtain stool specimens for analysis of contamination with the research agent.

All major, unusual or extended illnesses of laboratory workers should be screened by the medical service for possible occupational origin

and recorded for future reference. Also, first-aid and lost-time occupational accidents, as well as accidents without personal injury but which result in exposure of the worker to a potential hazardous organism, should be noted in the worker's individual medical case file together with the result of examinations deemed appropriate by the physician at that time.

The investigation of accidents associated with recombinant DNA research should also include a review of techniques, procedures and types and uses of equipment that may have been involved in the accident. The investigation should also establish the circumstances leading to the accident. In addition, the investigation report should provide recommendations for preventing similar occurrences.

#### 4. Medical Examinations

It is impossible to make specific recommendations concerning the need for either pre-assignment or periodic medical examinations for laboratory workers engaged in recombinant DNA research. Such recommendations must be determined on a case by case basis and will depend on the assessed hazards of the project and the individual needs of the laboratory worker. Where the potential for laboratory-acquired illness is known to exist, medical examinations are appropriate. Pre-assignment medical examinations, in this case, will establish base-line data that may provide the basis for comparison in the event a laboratory-acquired illness occurs.

If pre-assignment medical examinations are provided, they should include a medical history, physical examination, skin test for tuberculosis, serology, selected biochemical tests, a complete blood count, urinalysis, needed immunizations, vision testing and an audiometric examination. An electrocardiogram should be taken for persons over 40 years of age and a Papanicolau smear for women.

Periodic medical examinations of laboratory workers who are actively engaged in research with potentially hazardous organisms provide the opportunity to update the employee's work history and to ensure that the employee has the opportunity to bring to the attention of the medical service any condition which may require more extensive examination. Although scheduled periodic medical examinations would be the ideal, the realities of cost and the availability of medical manpower make individualized non-routine medical attention more rewarding to the laboratory worker and the institution alike. Updating the work and medical histories of the laboratory worker could be achieved by having the worker periodically prepare and transmit to the medical service an interval medical report. The medical service could review each report and determine whether medical consultation is required. Then an appointment could be scheduled with the laboratory worker, if necessary.



The following questions and requests for information would be recommended for inclusion in an interval medical report:

- Have you had any serious or extended illnesses since your last medical report?
- Have you been off work and/or hospitalized due to illness since your last medical examination or interval medical report.
- List the infectious agents you have been working with since your last medical examination or interval medical report.
- List the source(s) of DNA, the nature of inserted DNA sequences and the hosts and vectors you have used in recombinant DNA studies since your last medical examination or interval medical report.
- List all drugs or medications you use. Include prescriptions and over-the-counter medicines taken on a regular basis. Please state the name of each drug and the frequency with which it is taken. Be sure to note antibiotics and antacids.
- List any drugs or medication you take only occasionally (e.g., laxatives, pain medication).
- List any accidents that resulted in inoculations, ingestion or probable inhalation to recombinant DNA materials since your last medical examination or interval medical report.

Where a laboratory worker is maintained under an active medical surveillance program, it is recommended that a final medical examination be provided prior to termination of employment.

## 5. Medical Evaluation

Certain medical conditions may place a laboratory worker at increased risk. For example, laboratory workers who are undergoing treatment with steroids, immunosuppressive drugs or antibiotics, or are suffering from colitis, ileitis, active chronic diarrhea, or other gastrointestinal disorders, should have a medical evaluation to determine whether they should be engaged in research with potentially hazardous organisms during the time of their treatment or illness. Also pregnant women should be counseled as to the advisability of working in areas where the potential for exposure to potentially hazardous organisms is present. In order to ensure that appropriate guidance is provided, any changes in the health status of a laboratory worker, who is engaged in research with potentially hazardous organisms, should be brought to the attention of the medical service.

## 6. Records

The institution should maintain records of all laboratory workers who are involved in recombinant DNA research. As a minimum, these records should include a listing of the source DNA, vectors and host organisms used in recombinant DNA research and copies of all investigation reports concerning accidental exposures and serious or extended illnesses. These records should be included in the laboratory worker's medical file when the laboratory worker participates in an active medical surveillance program. Following termination of the laboratory worker's employment at the institution, the medical records should be maintained by a responsible medical authority for an appropriate period of time.

## E. Training Aids, Materials and Courses

### 1. Slide-Tape Cassettes

- Introduction to Biohazards Control: Stock No. 176.54 (\$56.00).
- Research Laboratory Safety: Stock No. 176.79 (\$90.00).
- Assessment of Risk in the Cancer Virus Laboratory: NAC No. 009770 (\$12.50).
- Hazard Control in the Animal Laboratory: NAC No. 009432 (\$12.50).
- Selection of a Biological Safety Cabinet: NAC No. 000709 (\$19.00).
- Effective Use of the Laminar Flow Biological Safety Cabinet: NAC No. 005133 (\$12.50).
- Certification of Class II (Laminar Flow) Biological Safety Cabinets: NAC No. 009771 (\$17.25).
- Formaldehyde Decontamination of the Laminar Flow Biological Safety Cabinet: NAC No. 005137 (\$12.50).
- Basic Principles of Contamination Control (in preparation), National Audiovisual Center.

#### Note:

1. The first two items may be ordered from the National Safety Council, 444 North Michigan Avenue, Chicago, Illinois 60611.
2. The remaining items may be ordered prepaid, with check or money order payable to the National Archives Trust Fund mailed to: Sales Branch, National Audiovisual Center (GSA), Washington, D. C. 20409.

## 2. Films

- Laboratory Design for Microbiological Safety (M-1090).
- World Within a World (M-3766-X).
- Infectious Hazards of Bacteriological Techniques (M-382).
- Controlling Infectious Aerosols: Part 1—Precautions in Microbiology (T-3621-X).
- Controlling Infectious Aerosols: Part 2—Minimizing Equipment-Related Hazards (T-3622-X).
- Air Sampling for Microbiological Particles (M-926).
- Surface Sampling for Microorganisms (Rodac Method) (M-924).
- Surface Sampling for Microorganisms (Swab Method) (M-925).
- Plastic Isolators: New Tools for Medical Research (M-599).
- Safe Handling of Laboratory Animals (M-455).
- Handling the Laboratory Mouse (T-2617-X).
- Handling the Laboratory Guinea Pig (T-2618-X).

Note: The above films are available on loan without charge from:  
Media Resources Branch, National Audiovisual Center (Annex),  
Station K, Atlanta, Georgia 30324.

### 3. Training Manuals for Animal Caretakers

- American Association for Laboratory Animal Science, 1967. Manual for Laboratory Animal Technicians, Publication 67-3, Box 10, Joliet, Illinois 60434.
- American Association for Laboratory Animal Science, 1972. Syllabus for the Laboratory Animal Technologist, Publication 72-2, 2317 West Jefferson Street, Suite 208, Joliet, Illinois 60434.
- Ralston-Purina Company, 1961. Copyright (updated annually). Manual for Laboratory Animal Care, Checkerboard Square, St. Louis, Missouri 63199.

#### 4. Training Courses

- Laboratory Safety Management

Sponsored or presented by the Center for Disease Control, Laboratory and Training Division, Bureau of Laboratories, Atlanta, Georgia 30333.

- Safety in the Laboratory

Sponsored or presented by the National Institute of Occupational Safety, Division of Training and Manpower Development, Robert A. Taft Laboratories, 4676 Columbia Parkway, Cincinnati, Ohio 45226.

- Biohazard and Injury Control in the Biomedical Laboratory.

- Biohazard Containment and Control for Recombinant DNA Molecules.

Note:

1. The last two courses are sponsored or presented by the National Cancer Institute, Office of Research Safety, NIH, Building 13, Room 2E45, Bethesda, Maryland 20014.
2. Information on dates and locations of courses can be obtained by writing to the sponsoring agency listed.

## F. Reference Bibliography on Biological Safety

Published literature on safety in the microbiological laboratory is extensive. This bibliography has been prepared to cite but a few of the important articles in this field. The citations have been organized under 11 topic areas for easy reference. These articles should prove useful to investigators, safety professionals, and institutional officials who wish to acquire a further understanding of the principles of safety in the microbiological laboratory.

### 1. Biological Safety Guides, Manuals, and Standards

Lenette, E.H., et al. 1974. Laboratory Safety Regulations, Viral and Rickettsial Disease Laboratory. California State Department of Health, Berkeley, CA.

Medical Research Council. 1977. Guidelines for Handling Recombinant DNA Molecules and Animal Viruses and Cells. Minister of Supply and Services Canada, Cat. No.: MR21-1/1977 ISBN 0-662-00587-2.

National Cancer Institute. 1975. Safety Standards for Research Involving Chemical Carcinogens. DHEW Publication No. (NIH) 76-900. NIH, NCI, Bethesda, MD.

National Cancer Institute. 1974. Safety Standards for Research Involving Oncogenic Viruses. DHEW Publication No. (NIH) 78-790. NIH, NCI, Bethesda, MD.

Public Services of Canada. 1973. Safety Guide for Laboratory Operations, Treasury Board Secretariat, Ottawa.

U. S. Army. 1969. Safety Regulations, Microbiological, Chemical and Industrial Safety. FDR-385-1, Fort Detrick, Frederick, MD.

U. S. Public Health Service. 1975. Lab Safety at the Center for Disease Control. DHEW Publication No. CDC 76-8118. USPHS, CDC, Atlanta, GA.

U. S. Public Health Service. 1974. NIH Biohazards Safety Guide. GPO Stock No. 1740-00383, Supt Documents, U. S. Government Printing Office, Washington, DC 20402 (\$3.85).



## 2. General Articles - Biosafety Overview

Chatigny, M.A. 1961. Protection against infection in the microbiological laboratory. Devices and procedures. In W.W. Umbreit, ed. *Advances in Applied Microbiology*, Vol 3, Academic Press, New York.

Collins, C.H., E.G. Hartley, and R. Pillsworth. 1974. The prevention of laboratory acquired infections. *Public Health Laboratory Service Monograph Series No. 6*, Her Majesty's Stationery Office, London.

Collins, C.H., and P.M. Lyne. 1970. Safety in the microbiological laboratory. In C.H. Collins and P.H. Lyne, eds. *Microbiological Methods*, University Park Press, Baltimore, MD.

Darlow, H.M. 1960. An introduction to safety in the microbiological laboratory. *Lab Pract* 9:777-785.

Darlow, H.M. 1969. Safety in the microbiological laboratory. In J.R. Norris and R.W. Ribbons, eds. *Methods in Microbiology*, Academic Press, New York, pp 169-204.

Hellman, A. 1969. Biohazard control and containment in oncogenic virus research. *USPHS, NIH, NCI, Bethesda, MD*.

Phillips, G.B. 1969. Control of microbiological hazards in the laboratory. *Am Ind Hyg Assoc J* 30:170-176.

Phillips, G.B. 1965. Microbiological hazards in the laboratory. *J Chem Education*, Part I - Control 42:A43-A48, Part II - Prevention 42:A117-A130.

Shapton, D.A., and R.G. Board, eds. 1972. *Safety in microbiology*. Academic Press, New York.

Songer, J.R., and J.F. Sullivan. 1974. Safety in the biological laboratory. *J Chem Ed* 51:A481-A485.

Wedum, A.G. 1974. Biohazard Control. In E.C. Melby, Jr. and N.H. Altman, eds. *Handbook of Laboratory Animal Science*, Vol I, CRC Press, Inc., Cleveland, OH 44128.

### 3. Laboratory Infections - Etiological Agents

American Hospital Association. 1974. Infection Control in the Hospital, Third Edition, American Hospital Association, 840 North Lake Shore Drive, Chicago, IL 60611.

Hanel, E., and R.H. Kruse. 1967. Laboratory-acquired mycosis. Misc Publ 28, AD665376. Frederick Cancer Research Center, P. O. Box B, Frederick, MD.

Hubbert, W.T., W.F. McCulloch, and P.R. Schnurrenberger. 1975. Diseases Transmitted from Animal to Man, 6th Ed., Charles C. Thomas, Springfield, IL.

Phillips, G.B. 1975. Laboratory Infections Bibliography. Becton, Dickinson and Company Research Center, Research Triangle Park, NC 27709.

Pike, R.M. 1976. Laboratory associated infections: summary and analysis of 3,921 cases. Health Lab Sci 13(2):105-114.

Pike, R.M., S.E. Sulkin, and M.L. Shulze. 1965. Continuing importance of laboratory-acquired infections. Am J Public Health 55:190-199.

Smadel, J.E. 1951. The hazard of acquiring virus and rickettsial diseases in the laboratory. Am J Public Health 41:788-795.

U. S. Public Health Service. 1976. Classification of Etiologic Agents on the Basis of Hazard, 4th Ed., USDHEW, CDC, Atlanta, GA 30333, pp 1-13.

#### 4. Biohazards

Andersen, R.E., L. Stein, M.L. Moss, and N.H. Gross. 1952. Potential infectious hazards of common bacteriological techniques. *J Bact* 64, 473.

Baldwin, C.L., J.F. Lemp, and M.S. Barbeito. 1975. Biohazard assessment in large-scale zonal centrifugation. *Appl Microbiol* 29:484-490.

Barbeito, M.S., R.L. Alg, and A.G. Wedum. 1961. Infectious bacterial aerosol from dropped petri dish cultures. *Am J Med Tech*, Nov-Dec, pp 318-322.

Barbeito, M.S., C.T. Matthews, and L.A. Taylor. 1967. Microbiological laboratory hazard of bearded men. *Appl Microbiol* 15:899-906.

Collins, C.H. 1976. The bacteriologist's loop: A biohazard. *The Gazette, IMLS* 20, 55.

Hanel, E., Jr., and R.L. Alg. 1955. Biological hazards of common laboratory procedures. II. The hypodermic syringe and needle. *Am J Med Tech* 21:343-346.

Harvey, R.W.S., T.H. Price, and D.H.M. Joynson. 1976. Observations on environmental contamination in a microbiological laboratory. *J Hyg Camb* 76:91-96.

Hellman, A., M.N. Oxman, and R. Pollack, eds. 1973. Biohazards in biological research. In *Proc of Conference held at Asilomar Conference Center, Pacific Grove, CA. Jan 22-24. Cold Spring Harbor Laboratory, P. O. Box 100, Cold Spring Harbor, NY 11724.*

Idoine, L.S., ed. 1973. Centrifuge Biohazards. *Proc of Cancer Research Safety Symposium. Frederick Cancer Research Center, Frederick, MD.*

Kanner, O. 1965. Contamination risk with screw-capped centrifugation tubes. *Am Rev Resp Dis* 91:439.

Oya, A. 1975. Biohazards in the field of microbiology. *Proc 6th International Symposium on Leukemia Research. University of Tokyo Press, Tokyo.*

Phillips, G.B. 1965. Causal factors in microbiological laboratory accidents and infections. *Fort Detrick Misc Publication 2, Fort Detrick, Frederick, MD.*

- Phillips, G.B., and S.P. Bailey. 1966. Hazards of mouth pipetting. *Am J Med Tech* 32:127/91-129/93.
- Phillips, G.B., and M. Reitman. 1956. Biological hazards of common laboratory procedures. IV. The inoculating loop. *Am J Med Tech* 22:16-17.
- Reitman, M., et al. 1954. Potential infectious hazards of laboratory techniques. I. Lyophilization. *J Bact* 68(5):541-544.
- Reitman, M., et al. 1954. Potential infectious hazards of laboratory techniques. II. The handling of lyophilized cultures. *J Bact* 68(5):545-548.
- Reitman, M., et al. 1954. Potential infectious hazards of laboratory techniques: III. Viral techniques. *J Bact* 68(5): 549-554.
- Reitman, M., and G.B. Phillips. 1955. Biological hazards of common laboratory procedures. I. The pipette. *Am J Med Tech* 21:338-342.
- Reitman, M., and G.B. Phillips. 1956. Biological hazards of common laboratory procedures. III. The centrifuge. *Am J Med Tech*. Jan-Feb.
- Reitman, M., and A.G. Wedum. 1966. Microbiological safety. *Public Health Rep* 71:659-665.
- Turner, A.G., J.R. Wilkins, III, and J.G. Craddock. 1975. Bacterial aerosolization from an ultrasonic cleaner. *J Clinical Microbiology* 1(3):289-293.
- Wedum, A.G., and R.H. Kruse. 1969. Assessment of human infection in the microbiological laboratory, 2nd Ed. Misc Publication #30. Dept of the Army, Fort Detrick, Frederick, MD.

## 5. Biological Aerosols

- Dautrebande, L. 1962. *Microaerosols*. Academic Press, New York.
- Dimmick, R.L., ed. 1963. *A symposium on aerobiology*. Naval Biological Laboratory, Naval Supply Center, Oakland, CA.
- Dimmick, R.L., and A.B. Akers, eds. 1969. *An Introduction to experimental aerobiology*. John Wiley and Sons, Inc., New York.
- Hatch, T.F., and P. Gross. 1964. *Pulmonary deposition and retention of inhaled particles*. Academic Press, New York.
- Hers, J.F. Ph., and K.C. Winkler. 1973. *Airborne transmission and airborne infection*. John Wiley and Sons, Inc., New York.
- McDermott, W., ed. 1960. *Conference on Airborne Infection*. The Williams and Wilkins Company, Baltimore, MD.
- Riley, R.L., and F. O'Grady. 1961. *Airborne infection, transmission and control*. The Macmillan Company, New York.
- Rosenburg, T. 1947. *Experimental air-borne infection*. The Williams and Wilkins Company, Baltimore, MD.
- Rutter, D.A., and C.G.T. Evans. 1972. *Aerosol hazards from some clinical laboratory apparatus*. *Brit Med J* 1:594-597.
- Silver, I.H., ed. 1970. *Aerobiology*. Proc 3rd International Symposium. University of Sussex, England, Sept 1969. Academic Press, New York.
- Wedum, A.G. 1964. *Airborne infection in the laboratory*. *Am J Public Health* 64:1669-1673.
- Wedum, A.G. 1964. *Laboratory safety in research with infectious aerosols*. *Public Health Rep* 79:619-633.
- Wells, W.F. 1955. *Airborne contagion and air hygiene*. Harvard University Press, Cambridge, MA.

## 6. Biological Laboratory Design

Anonymous. 1975. A total containment facility for animal research. *Lab Animal* May/June, 25-36.

British Standards Institution. 1959. Recommendations on laboratory furniture and fittings. Section 3 Recommendations on fume extraction in laboratories. British Standard 3202, London: BSI.

Brown, S.S. 1971. Laboratory design and chemical hazards. *Ann Clin Biochem* 8, 125.

Everett, K., and D. Hughes. 1975. A guide to laboratory design. London: Butterworths.

Hare, R., and P.N. O'Donoghue, eds. 1968. The design and function of laboratory animal houses (Laboratory Animals Symposia 1). London: Laboratory Animals Centre.

Phillips, G.B. 1963. Programming for Isolation, Quarantine and Infectious Disease Facilities - Discussion. *Lab An Care* 13:289-291.

Phillips, G.B., and R.S. Runkle. 1967. Laboratory design for microbiological safety. *Appl Microbiol* 15:378-389.

Runkle, R.S., and G.B. Phillips. 1969. Microbial containment control facilities. Van Nostrand Reinhold Company, New York.

Wedum, A.G., and G.B. Phillips. 1964. Criteria for design of a microbiological research laboratory. *Am Soc Heating, Refrigeration and Air Conditioning* 6:46-52.

## 7. Biological Safety Cabinetry

Baldwin, C.L., and P.H. Errico. 1975. Biological safety cabinets for contamination control. *J Chem Ed* 52(2):A545-A549.

Coriell, L.L., and G.J. McGarrity. 1968. Biohazard hood to prevent infection during microbiological procedures. *Appl Microbiol* 16(12):1895-1900.

Darlow, H.M. 1967. The design of laboratory safety cabinets. *Chem & Ind*, p 1914.

Evans, C.G.T., R. Harris-Smith, and J.E.D. Stratton. 1972. The use of safety cabinets for the prevention of laboratory-acquired infection. In *Safety in Microbiology*, D.A. Shapton, R.G. Board, eds., p 21. Soc for Applied Bacteriology Technical Series No. 6, London: Academic Press.

Kukla, H.E. 1971. Evaluation of a vertical airflow microbiological cabinet. *Am Assoc Contam Control J* 3:5-10.

Line, S.J. 1972. Safety of portable inoculation cabinets. *J Clin Path* 25, 93.

National Sanitation Foundation. 1976. NSF Standard No. 49 for Class II (Laminar Flow) Biohazard Cabinetry. NSF, NSF Building, Ann Arbor, MI 48105.

Phillips, G.B., and R.S. Runkle. 1973. Biomedical application of laminar airflow. Research Center, Becton, Dickinson and Company, Raleigh, NC.

U. S. Department of Health. 1973. Biological safety cabinets. Atlanta, GA: U. S. Department of Health, Education, and Welfare, Public Health Service.

Webb, N.L., B.M. Richards, and A.P. Gooders. 1975. The total containment of a batch-type zonal centrifuge. *Biotechnology and Bioengineering* 17(9):1313-1322.

Yalden, M.J. 1972. Laminar flow as applied to bacteriology. In *Safety in Microbiology*, D.A. Shapton and R.G. Board, eds., p 49. Society for Applied Bacteriology Technical Series No. 6, London: Academic Press.

## 8. Biological Safety Equipment

British Standards Institution. 1969. Mechanical safety requirements for laboratory centrifuges, British Standard 4402, London: BSI.

Dowsett, E.G., and J.F. Heggie. 1972. Protective pathology laboratory coat. *Lancet* i, 1271.

Gillespie, E.H., and S.A. Gibbons. 1975. Autoclaves and their dangers and safety in laboratories. *J Hyg Camb* 75, 475.

Guyton, H.G., and H.M. Decker. 1963. Respiratory protection provided by five new contagion masks. *Appl Microbiol* 11:66-68.

Halbert, M.M., D. Vesley, and N. Vick. 1974. Pipetting aids and other safety devices for the biomedical laboratory. School of Public Health. University of Minnesota. St. Paul.

Hall, C.V. 1975. A biological safety centrifuge. *Health Laboratory Science* 12(2):104-106.

Hillman, M.R., and R.O. Taylor. 1958. A safe high-speed blender for infectious material. *J Lab & Clin Med* 51:977-980.

Jemski, J.V., and G.B. Phillips. 1963. Microbiological safety equipment. *Lab Animal Care* 13:2-12.

Johnson, J.C., and J.T. August. 1976. A device for pipetting hazardous materials within biological containment cabinets. *Annal Biochem* 73(1):262-264.

Law, S.E. 1972. Respirators and masks. *Agri Eng* 53(11):12-14.

Reitman, M., M.A. Frank, M.R. Alg, and A.G. Wedum. 1953. Infectious hazards of the high speed blender and their elimination by a new design. *Appl Microbiol* 1, 14.

Songer, J.R. 1978. Safe, convenient, portable pipettor. *Applied and Environmental Microbiology*. May.

Songer, J.R., J.L. Riley, and D.T. Brayman. 1971. Self-sterilizing inoculating loop. *Appl Microbiol* 21:1095-1096.

Songer, J.R., J.F. Sullivan, and J.W. Monroe. 1971. Safe convenient pipetting device. *Appl Microbiol* 21:1097-1098.



9. Safety Procedures and Practices

Anon. 1968. Good Laboratory Practices Manual. National Cancer Institute. Bethesda, MD.

Brayman, D.T., J.R. Songer, and J.F. Sullivan. 1974. Effectiveness of footwear decontamination methods for preventing the spread of infectious agents. Lab An Sci 24:888-894.

Committee of Vice Chancellors and Principals of the Universities of the United Kingdom. Safety in universities, code of practice. Part 1. General principles. London: Association of Commonwealth Universities for Committee of Vice Chancellors and Principals.

Grieff, D. 1969. Safe procedure for opening evacuated glass ampoules containing dried pathogens. Appl Microbiol 18:130.

Maier, S., and J.V. Lawrence. 1968. Simple method to reduce aerosol contamination in blending operations. Appl Microbiol 16:176.

## 10. Disinfection and Sterilization

Bernarde, M.A. 1970. Disinfection. Marcel Decker, Inc., New York.

Block, S.S. 1977. Disinfection, Sterilization and Preservation, 2nd Ed. Lea and Febiger, Philadelphia, PA.

Borick, P.M. 1973. Chemical sterilization. Dowden, Hutchinson and Ross, Inc., Stroudsburg, PA.

Litsky, B.Y. 1966. Hospital Sanitation - An Administrative Program. Clissold Publishing Co., Chicago, IL.

Perkins, J.J. 1956. Principles and methods of sterilization. Charles C. Thomas. Springfield, IL.

Phillips, G.B., and W.S. Miller. 1973. Industrial Sterilization. Duke University Press, Durham, NC.

Songer, J.R., et al. 1972. The practical use of formaldehyde vapor for disinfection. Hls Lab Sci 9(1):46-55.

Spalding, E.H. 1972. Chemical disinfection and antisepsis in the hospital. J Hospital Research 9:5-31.

Sykes, G. 1965. Disinfection and Sterilization, 2nd Ed. J. B. Lippencott Co., Philadelphia, PA.

Taylor, L.A., M.S. Barbeito, and G.G. Gremillion. 1969. Para-formaldehyde for surface sterilization and detoxification. Appl Microbiol 17:614-618.

U. S. Public Health Service. 1977. Use of ethylene oxide as a sterilant in a medical facility. DHEW (NIOSH) Publication No. 77-200, NIOSH, Rockville, MD.

Walker, J.F. 1964. Formaldehyde, 3rd Ed. Reinhold Publishing Corporation, New York.

## 11. Animal Handling

American Association for Laboratory Animal Science. 1967. Manual for Laboratory Animal Technicians, Publication 67-3, Box 10, Joliet, IL.

American Association for Laboratory Animal Science. 1972. Syllabus for the laboratory animal technologist, Publication 72-2, 2317 W. Jefferson Street, Suite 208, Joliet, IL 60434.

Arrington, L.R. 1972. Introductory animal science - the breeding, care and management of experimental animals. The Interstate Printers and Publishers, Inc., Danville, IL.

Code of Federal Regulations, Title 9 - Animals and Animal Products. For sale by Supt of Documents, Government Printing Office, Washington, DC.

Gay, W.I., ed. 1965. Methods of animal experimentation, Vol 1, Academic Press, New York.

Kruse, R.H., and A.G. Wedum. 1965. Recovery of microorganisms from urine and feces of infected animals. Fort Detrick Misc Publication #12, Fort Detrick, Frederick, MD.

Medical Research Council. 1961. Report of a Symposium on Hazards of the Animal House (Collected papers, Vol 10). Carshalton: Laboratory Animals Centre, Medical Research Council.

Melby, E.C., and N.H. Altman, eds. 1974-1976. Handbook of Laboratory Animal Science. Vols I, II, III, CRC Press, Inc., Cleveland, OH.

Perkins, F.T., and P.N. O'Donoghue. 1969. Hazards of handling simians. Laboratory Animal Handbook 4, Laboratory Animals, Ltd., London.

Ralston-Purina Company. 1961. Copyright (updated annually). Manual for Laboratory Animal Care, Checkerboard Square, St. Louis, MO 63199.

Seamer, J. 1972. Safety in the animal house. Laboratory Animal Handbook 5, Laboratory Animals, Ltd., London.

U. S. Public Health Service. 1974. Guide for the care and use of laboratory animals. DHEW Publication No. (NIH) 74-23. U. S. Government Printing Office, Washington DC. Stock No. 1740-0343, price 70¢.

Universities Federation for Animal Welfare. 1976. The UFAW Handbook on the Care and Management of Laboratory Animals, Churchill Livingstone, Edinburg, London, New York.

## VII. NCI Guidelines for Control of Moderate Risk Oncogenic Viruses

In 1974, the National Cancer Institute issued Safety Standards for Research Involving Viruses. Control practices for moderate risk oncogenic viruses are included here to provide additional guidance to investigators who may use these viruses in recombinant DNA research. All known oncogenic viruses not presently classified as moderate risk oncogenic viruses may be safely handled by employing physical containment practices that are consistent with P2 requirements.

### A. Moderate Risk Oncogenic Viruses

1. RNA Tumor Viruses: Feline Leukemia  
Feline Sarcoma  
Woolly Monkey Fibrosarcoma  
Gibbon Ape Lymphosarcoma
2. DNA Tumor Viruses: Herpesvirus saimiri  
Herpesvirus ateles  
Yaba Pox Virus  
Epstein-Barr Virus

### B. Medical Surveillance

#### 1. Preassignment Examinations

An appropriate preassignment physical examination shall be provided each person planning to work with moderate risk oncogenic viruses. The purpose of this examination is to establish a baseline against which changes can be measured and to determine whether there are any medical conditions that may lead to increased risk.

## 2. Periodic Examinations

Persons working with moderate risk oncogenic viruses shall be provided periodic physical examinations. The frequency shall be dependent upon the work circumstances and the age and sex of the employee.

## 3. Medical Evaluation

Persons with reduced immunologic competency, pregnant women, and patients under treatment with steroids or cytotoxic drugs shall receive a medical evaluation before work in areas where moderate risk oncogenic viruses are used.

## 4. Serum Collection

Serum shall be collected at the time of the preemployment physical examination to establish a baseline reference and on a semiannual basis thereafter in order to monitor serological changes. Serum also shall be collected prior to termination of employment and immediately after an accidental exposure and at an appropriate interval thereafter for serological testing.

## C. Personnel Practices

### 1. Protective Clothing

a. Gloves shall be worn when using oncogenic viruses. Clean laboratory clothing shall be provided at least weekly. Protective clothing contaminated by oncogenic viruses shall be autoclaved.

b. Animal handlers shall use a complete clothing change, including pants and shirts or jumpsuits, safety-toed shoes or boots, head covers, and gloves. Clean clothing shall be provided at least weekly. Clothing contaminated by oncogenic viruses shall be autoclaved.

### 2. Protective Equipment

Personnel engaged in animal procedures where exposure to airborne particulates contaminated with oncogenic viruses could occur shall wear an appropriate half-face, filter-type mask. The mask shall not be worn outside the work area.

### 3. Eating, Drinking, and Smoking

There shall be no eating, drinking, smoking, chewing of gum or tobacco, application of cosmetics or storage of food in laboratories where oncogenic viruses are used.

### 4. Pipetting

Mechanical pipetting aids shall be used for all pipetting procedures.

## D. Operational Practices

### 1. Access Control

a. The universal Biohazard symbol shall be prominently displayed at access points to all work areas where moderate risk viruses are used.

b. Only persons authorized by the laboratory supervisor shall enter work areas displaying the Biohazard symbol.

### 2. Identification and Storage of Materials

a. Storage vessels containing oncogenic viruses shall be labeled to provide identification of their contents.

b. An inventory of all oncogenic viruses shall be maintained.

### 3. Laboratory Transport

a. Nonbreakable impermeable closed containers shall be used during transport of oncogenic viruses through a building corridor or between buildings.

b. Contaminated materials that are transferred from work sites to decontamination and disposal staging areas shall be transported in a manner that prevents accidental spills.

### 4. Housekeeping

Housekeeping procedures that suppress the formation of aerosols such as the use of a wet mop or a vacuum cleaner equipped with a high-efficiency particulate air (HEPA) filter on the exhaust shall be used.

Dry sweeping and dry mopping shall be kept to a minimum.

5. Decontamination and Disposal

a. Contaminated glassware and similar materials shall be decontaminated before washing or disposal.

b. Liquid wastes containing oncogenic viruses shall be decontaminated, either chemically or by heat, before being discharged to the community sanitary sewer system.

c. Other contaminated wastes and animal carcasses shall be collected in impermeable containers that are closed prior to removal from the work area. Disposal shall be by incineration or other appropriate methods.

6. Packaging and Shipping

The packaging and shipping methods established by the Department of Health, Education, and Welfare for the transportation of etiologic agents [42CFR 72.25(c), 1972] shall be followed for all moderate risk viruses.

7. Vacuum Lines

Each vacuum service shall be protected with a disposable HEPA filter and a liquid trap. The effluent from aspiration of liquid containing oncogenic viruses should be collected in liquid traps containing concentrated disinfectant.

E. Biological Safety Cabinets

1. Use of Biological Safety Cabinets

a. Aerosol-generating processes such as blending, grinding, and sonicating shall be contained in biological safety cabinets.

b. Cell culture procedures involving moderate risk viruses shall be contained in biological safety cabinets.

c. Inoculated animals shall be kept in ventilated, ultraviolet, or filter top cages.

## 2. Performance Requirements

- a. Ventilated safety cabinets shall be tested annually.
- b. The average velocity of the airflow through the work opening of the cabinet shall be a minimum of 75 feet per minute.
- c. The exhaust air from ventilated safety cabinets shall be filtered with HEPA filters.

## F. Facilities

Directional airflow shall be provided in laboratory areas and animal rooms where moderate risk oncogenic viruses are used. Air shall flow in the direction from areas of least potential contamination toward areas of greatest potential contamination. No recirculation of exhaust air from these areas shall be permitted without appropriate treatment.